

D Ersatzteilliste	Motorsäge 637	Inhaltsverzeichnis Seite
	Gültig für	Motoreinheit / Zündung / Lüfterrad 2
	Modell ab 2006,	Luftfilter, Vergaser, Auspuff 3
	Seriennummer ab:	Hauptgehäuse 4
	2734	Ölpumpe, Kupplung, Schwertabdeckung 5
		Starter 6
		Bügel / Handgriff 7
		Schwert, Kette, Anschlagkralle 8
		Werkzeug, Zubehör (optional) 9
		Ersatzteile 11
		Richtlinien für die Bestellung 11
GB Spare parts list	Chain saw 637	Table of contents Page
	Type 2006 →	Engine / ignition coil / fan wheel 2
	as of serial no. 2734	Air filter, carburetor, exhaust 3
		Main housing 4
		Oil-pump, clutch, chain guard 5
		Starter 6
		Handle bar 7
		Guide bar, chain, bucking spike 8
		Tools, accessories (optional) 9
		Spare parts 11
		Directions for Ordering 11
F Liste de pièces de rechange	Tronçonneuses 637	Table des matières Page
	Modélo 2006 →	Moteur / bobine allumage / turbine 2
	à partir de no. de série	Filtre à air, carburateur, echappement 3
	2734	Carter principal 4
		Pompe à huile, embrayage, carter de chaîne 5
		Lanceur 6
		Etrier 7
		Guide chaîne, chaîne, griffe de butée 8
		Outils, accesories (optional) 9
		Pièces de rechange 11
		Directives pour les commandes 11
E Lista de piezas de recambio	Motosierras 637	Indice Página
	Modelo 2006 →	Motor / bobina / turbina 2
	desde de no. de serie	Filtro de aire, carburador, escape 3
	2734	Carter principal 4
		Bomba de aceite, embrague, cubierta espada 5
		Arranque 6
		Asa 7
		Espada, cadena, garra de 8
		Herramientas, accesorios (opcionale) 9
		Piezas de recambio 11
		Directivas de pedido 11



Bild-Nr. Pos.-No. No.Pos. Pos.-No.	Bestell-Nr. Order-No. No. de Cde Ref.-Nr.	Menge Quantity Nombres Cantidad	Motoreinheit / Zündung / Lüfterrad	Engine / ignition coil / fan wheel	Moteur / bobine allumage / turbine	Motor / bobina / turbina
1	21 00 240	1	Motoreinheit enth. (-> 1 - 15	Engine incl. (-> 1 - 15	Moteur y inclus (-> 1 - 15	Motor incl. (-> 1 - 14
2	22 00 987	1	Nikasilzylinder Ø 40 mm	Cylinder	Cylindre	Cilindro
3	22 00 153	1	Kolben Ø 40 mm enth. (-> 3 - 5	Piston incl. (-> 3 - 5	Piston y inclus (-> 3 - 5	Piston incl. (-> 3 - 5
4	20 48 140	1	Kolbenring 40x1,5 mm	Piston ring	Segment	Anillo de piston
5	00 55 278	2	Sicherungsring 9x0,8 mm <-)	Piston pin circlip <-)	Clip d'axe piston <-)	Anillo de seguridad <-)
6	20 31 117 25	1	Kolbenbolzen 9/6x28 mm	Piston pin	Axe de piston	Bulon de piston
7	22 00 243 52	1	Kurbelwelle	Crankshaft	Vilebrequin	Cigüenal
8	21 00 364 25	2	Lagerhülse 12x38,17x17 mm enth. (-> 8, 9	Sleeve incl. (-> 8, 9	Douille y inclus (-> 8, 9	Casquillo incl. (-> 8, 9
9	00 62 280	2	O-Ring <-)	O-ring <-)	Joint torique <-)	Anillo <-)
10	00 54 237	2	Wellendichtring 12x25x5 mm	Oil seal	Joint spy	Reten
11	20 63 370	2	Kurbelgehäusedichtung	Gasket	Joint	Junta
12	61 00 134	1	Kurbelgehäuse	Crankcase	Carter vilebrequin	Carter cigüenal
13	00 72 140	4	Tellerscheibe 5,2x12x0,5 mm	Spring washer	Ressort	Muelle de disco
14	00 18 340	4	Zylinderschraube M5x40 mm	Screw	Vis	Tornillo
15	00 55 226	1	Nadelkäfing 9x13x12,5 mm <-)	Needle sleeve <-)	Douille <-)	Casquillo <-)
20	23 00 481	1	Zündmodul enth. (-> 20 - 24	Ignition coil incl. (-> 20 - 24	Bobine allumage y inclus (-> 20 - 24	Bobina incl. (-> 20 - 24
21	00 66 455	1	Kabelband 98x2,5 mm, schwarz	Cable band	Frein de câble	Cinta
22	00 61 130	1	Klebefilz	felt	feutre	fieltro
23	00 84 621	1	Kerzenstecker	Spark plug cap	Capuchon de bougie	Tapa de bujia
24	00 73 360	1	Kontaktfeder	Contact spring	Ressort de contact	Resorte de contacto
25	23 00 730	1	Zündkerze WSR6F200	Spark plug	Bougie	Bujia
26	00 30 101	1	Scheibe 4,3 mm	Washer	Rondelle	Arandela
27	00 72 148	2	Sicherungsscheibe 4 DIN 6796 A	Washer	Rondelle	Disco de tension
28	00 18 327	2	Zylinderschraube M4x20 mm	Screw	Vis	Tornillo
30	24 00 278	1	Lüfterrad	Fan wheel	Turbine	Turbina
31	00 72 141	1	Scheibe 9,2x18x0,7 mm	Washer	Rondelle	Arandela
32	00 20 145	1	Sechskantmutter M8x1 mm	Screw	Vis	Tornillo
40	00 55 134	1	Sicherungsring 12x1 mm	Circlip	Circlip	Anillo de seguridad
41	00 31 194	1	Passscheibe 12x18x0,5 mm	Washer	Rondelle	Arandela



Bild-Nr. Pos.-No. No.Pos. Pos.-No.	Bestell-Nr. Order-No. No. de Cde Ref.-Nr.	Menge Quantity Nombres Cantidad	Luftfilter, Vergaser, Auspuff	Air filter, carburetor, exhaust	Filtre à air, carburateur, échappement	Filtro de aire, carburador, escape
1	00 71 153	2	Ringfeder	Spring ring	Bague ressort	Resorte
2	60 63 101	1	Verbindungsschlauch	Hose connection	Raccord admission	Tubo
3	00 60 120	1	Isolierplatte	Insulating plate	Plaque isolatrice	Chapa
4	00 64 319	1	Schlauch 5x1,5x45 mm	Hose	Tuyau	Tubo
5	00 18 274	3	Linsenschraube 5x16 mm	Screw	Vis	Tornillo
6	23 00 815	1	Vergaserstutzen	Manifold	Bride de carburateur	Brida carburador
7	00 66 381	1	Winkelstutzen 3x12,5 mm	Elbow	Raccord coude	Racor
8	00 64 300	1	Schlauch 3x1,5x195 mm	Hose	Tuyau	Tubo
9	20 61 514	1	Dichtung 0,5mm	Manifold gasket	Joint bride carburateur	Junta de brida
10	20 74 905	1	Haltering	Retaining ring	Bague de support	Anillo soporte
11	23 00 138 10	1	Vergaser enth. (-> 11, 12	Carburetor incl. (-> 11, 12	Carburateur y inclus (-> 11, 12	Carburador incl. (-> 11, 12
12	60 74 636	1	Rasthebel <->	Stop lever <->	Levier d'arrêt <->	Palanca de engaste <->
13	25 00 209	1	Filtergehäuse	Filter housing	Carter filtre	Carter de filtro
14	00 18 226	2	Linsenschraube 5x40 mm	Screw	Vis	Tornillo
15	20 48 390	1	Filterplatte	Filter plate	Plaque filtre	Chapa filtro
16	20 48 389	1	Filterschaumplatte	Filter foam plate	Plaque filtre	Chapa filtro
17	60 74 116	1	Deckel	Cover	Couvercle	Cubierta
18	68 00 334 25	1	Filterschraube M5x16	Screw	Vis	Tornillo
19	00 69 767	1	SKS "SOLO"	Decal "SOLO"	Autocollant "SOLO"	Etiqueta "SOLO"
20	05 10 985	1	Dichtsatz Vergaser WT	Gasket	Pochette - carburateur	Juego de juntas
21	05 10 984	1	Reparatursatz Vergaser WT	Repair	Kit de réparation carburateur	Juego de rep.
22	05 10 986	1	Drosselachsenkit Vergaser WT	Throttle axle kit	Kit axe clapet gaz carburateur	Juego de eje
23	05 10 987	1	Chokeachsenkit Vergaser WT	Choke axle kit	Kit axe de choke	Juego eje choke
30	00 18 110	2	Vierkantschraube M5x50	Screw	Vis	Tornillo
31	20 61 516	1	Auspuffdichtung	Muffler gasket	Joint amortisseur	Junta del escape
32	25 00 814	1	Auspuff	Exhaust	Echappement	Escape
33	00 72 144	6	Sicherungsscheibe 5 mm	Tension washer	Rondelle de tension	Arandela elastica
35	00 28 137	2	Sechskantmutter M5	Nut	Contre-écrou	Tuerca
38	00 18 399	1	Zylinderschraube M5x35 mm	Screw	Vis	Tornillo

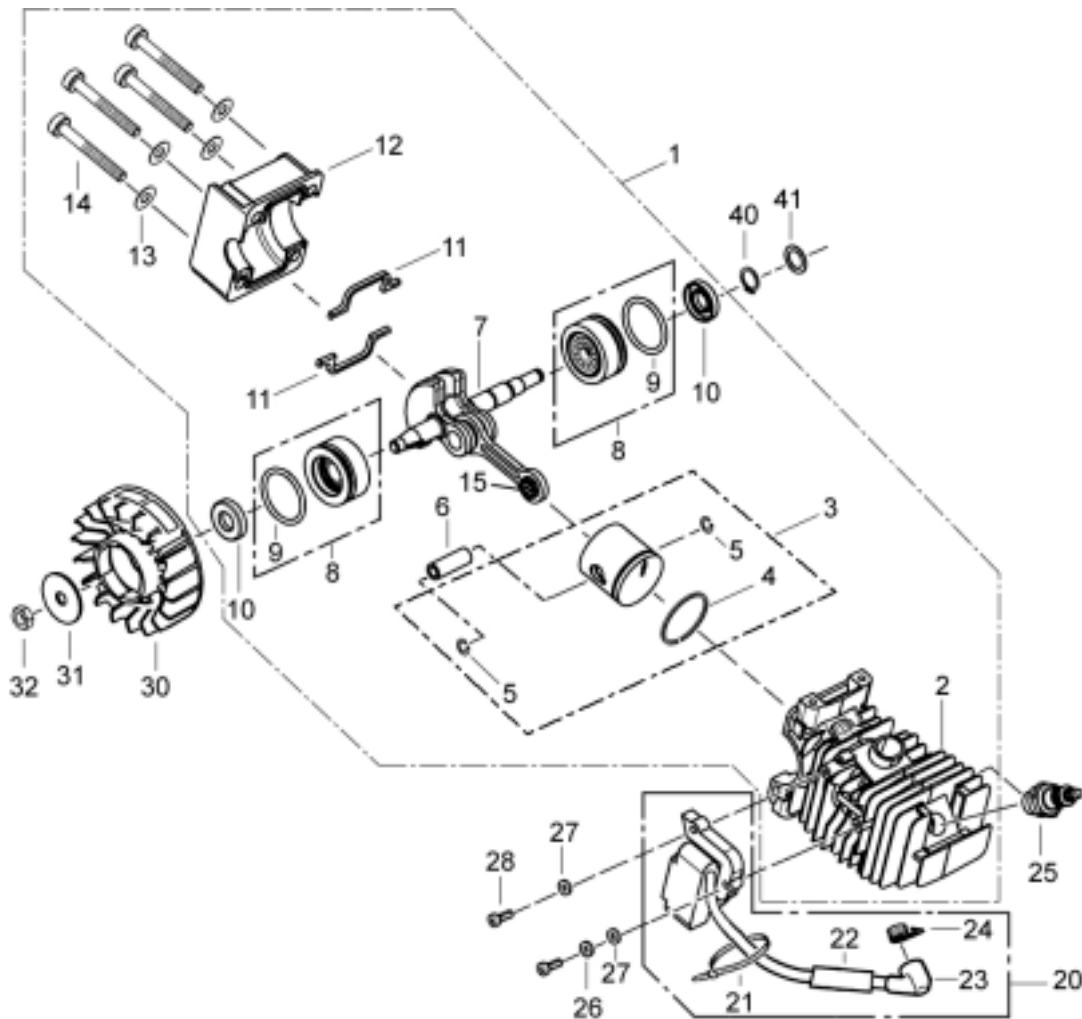

Bild-Nr. Pos.-No. No.Pos. Pos.-No.	Bestell-Nr. Order-No. No. de Cde Ref.-Nr.	Menge Quantity Nombres Cantidad	Hauptgehäuse	Main housing	Carter principal	Carter principal
1	61 00 135	1	Hauptgehäuse enth. (-> 1 - 12)	Main housing incl. (-> 1 - 12)	Carter principal y inclus (-> 1 - 12)	Carter principal incl. (-> 1 - 12)
2	00 40 188	1	Zylinderstift 5H 8x14	Pin	Goupille	Tornillo
3	00 18 380	1	Schwertstiftschraube M8x19/41	Screw	Vis	Tornillo
4	00 41 104	1	Schwertführungsbolzen	Bolt	Boulon	Perno
5	27 00 403	1	Rückschlagventil (Oiltank Entlüftung)	Check valve	Soupape antiretour	Palanca choke
6	27 00 348	1	Tankverschluss, Benzin enth. (-> 6, 7)	Tank cap incl. (-> 6, 7)	Bouchon reservoir y inclus (-> 6, 7)	Tapa de deposito incl. (-> 6, 7)
7	00 62 146	1	O-Ring 29,82x2,62 mm <-)	O-ring <-)	Joint torique <-)	Anillo <-)
8	27 00 326	1	Tankverschluss, Öl enth. (-> 8, 9)	Oil tank cap incl. (-> 8, 9)	Bouchon reservoir y inclus (-> 8, 9)	Tapa de deposito incl. (-> 8, 9)
9	00 62 147	1	O-Ring 25,3x2,4mm <-)	O-ring <-)	Joint torique <-)	Anillo <-)
10	27 00 416	1	Filter Benzinsucher	Fuel pick-up	Crépine d'essence	Filtro gasolina
11	20 63 212	1	Kraftstoffschlauch 3x107 mm	Tube	Durite	Manguera
12	00 73 352	1	Schlauchöse 8x0,7x3 mm <-)	Tube eye <-)	Collier <-)	Aro <-)
13	00 33 268 25	4	Distanzrohr 8x1,2x7,5 mm	Spacer	Entretoise	Pieza distanciadora
14	00 72 140	4	Tellerscheibe 5,2x12x0,5 mm	Spring washer	Ressort	Muelle de disco
15	00 18 423	4	Zylinderschraube M5x18 mm	Screw	Vis	Tornillo
16	60 74 121	2	Kappe	Cap	Capuchon	Chapa
17	00 64 441	1	Schlauch 3x1,5x200 mm	Hose	Tuyau	Tubo
18	27 00 322	1	Primer	Primer	Primer	Cabador
19	00 64 407	1	Schlauch 2x1,5x230 mm	Hose	Tuyau	Tubo
20	00 30 108	1	Scheibe 5,3 mm	Washer	Rondelle	Arandela
21	00 18 336	1	Zylinderschraube M5x16	Screw	Vis	Tornillo
22	50 74 562	1	Linsenschraube 5x10 mm	Screw	Vis	Tornillo
23	60 74 137	1	Stift Halbgas	Pin	Levier mi-gaz	Perno
24	60 74 136	1	Chochehebel	Choke lever	Levier choke	Palanca choke
25	27 00 426	1	Entlüftungsstutzen kompl. enth. (-> 25-27)	Ventilation hose compl. incl. (->25-27)	Tuyau de ventilation compl. y inclus (->25-27)	Tubo ventilación compl. incl. (->25-27)
26	27 00 430	1	Entlüftungsstutzen	Ventilation socket	Manchon d'aération	Munon
27	00 64 440	1	Schlauch 3x1,5x25 <-)	Hose <-)	Tuyau <-)	Tubo <-)
30	00 73 381	1	Drehfeder 1,3x7,1	Torsion spring	Ressort	Resorte

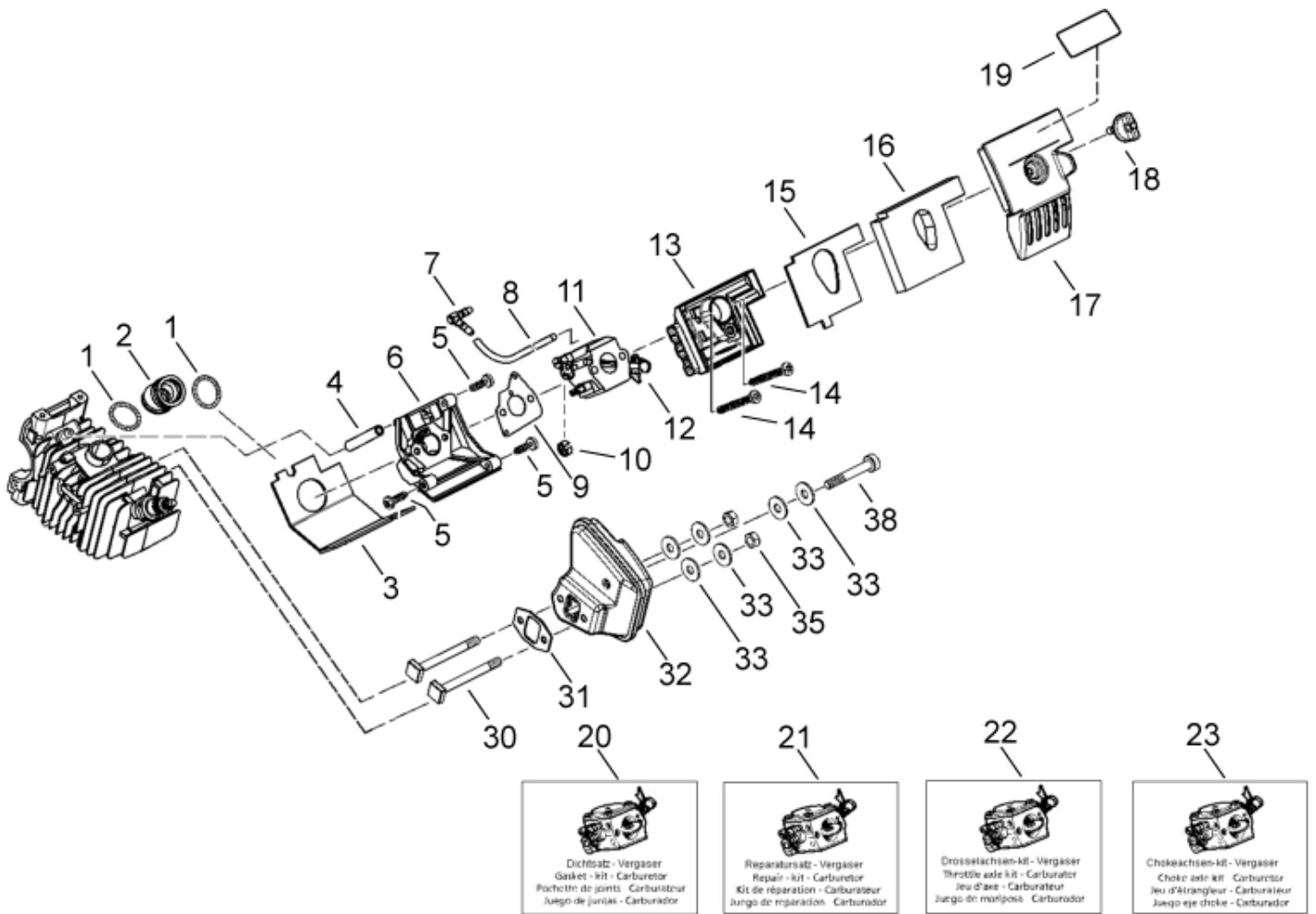

Bild-Nr. Pos.-No. No.Pos. Pos.-No.	Bestell-Nr. Order-No. No. de Cde Ref.-Nr.	Menge Quantity Nombres Cantidad	Ölpumpe, Kupplung, Schwertabdeckung	Oil-pump, clutch, chain guard	Pompe à huile, embrayage, carter de chaîne	Bomba de aceite, embrague, cubierta espada
1	60 74 120	1	Distanzhülse	Spacer sleeve	Entretoise	Espaciador
2	00 44 130	1	Hohlniet	Rivet	Rivet	Remache
3	60 74 650	1	Mitnehmerschnecke	Activator	Entraîneur à vis	Activador
4	64 00 106	1	Ölpumpe	Oil-pump	Pompe à huile	Bomba de aceite
5	00 30 108	1	Scheibe 5,3 mm	Washer	Rondelle	Arandela
6	00 18 363	1	Linsenschraube 5x20 mm	Screw	Vis	Tornillo
7	00 31 625	2	Scheibe 10x15x1,25 mm	Washer	Rondelle	Arandela
8	60 42 631	1	Scheibe 10x42x1 mm	Washer	Rondelle	Arandela
10	35 00 460	1	Fliehkraftkupplung M10x1	Centrifugal clutch	Embrayage centrifuge	Embrague centrifugal
11	35 00 433 25	1	Kupplungsglocke 3/8"	Clutch drum	Cloche embrayage	Campana embrague
12	62 00 134 25	1	Bremsband	Brake band	Ruban de frein	Cinta de freno
13	00 30 102	1	Scheibe 5,3 mm	Washer	Rondelle	Arandela
14	00 18 362	1	Linsenschraube 5x10 mm	Screw	Vis	Tornillo
15	00 70 253	1	Druckfeder 1,5x7x21,5 mm	Pressure spring	Ressort de pression	Resorte
16	63 00 175 25	1	Druckblech	Pressure plate	Levier de blocage frein de chaîne	Chapa de presión
17	63 00 208 25	1	Verstellung	Brake linkage	Poussoir ressort frein	Varilla
18	00 70 254	1	Druckfeder 1,6x10,2x56 mm	Pressure spring	Ressort de pression	Resorte
19	00 31 626	1	Scheibe 8,1x32x1 mm	Washer	Rondelle	Arandela
20	00 55 216	1	Sicherungsscheibe 6 mm	Safety washer	Circlips	Seguro
21	61 00 427	1	Schwertabdeckung	Chain guard	Carter de chaîne	Cubierta espada
22	60 31 993	1	Distanzbuchse 8,5x18,6/14,5x5,8 mm	Distance sleeve	Entretoise	Casquillo
23	00 20 214	1	Sechskantmutter M8	Nut	Écrou	Tuerca
24	00 69 106	1	SKS „SOLO“	Decal „SOLO“	Autocollant „SOLO“	Adhesivo „SOLO“
25	60 74 975	1	Bremsbandabdeckung	Brake band cover	Recouvrement frein de chaîne	Chapa cinta de freno
26	00 18 274	2	Linsenschraube 5x16 mm	Screw	Vis	Tornillo

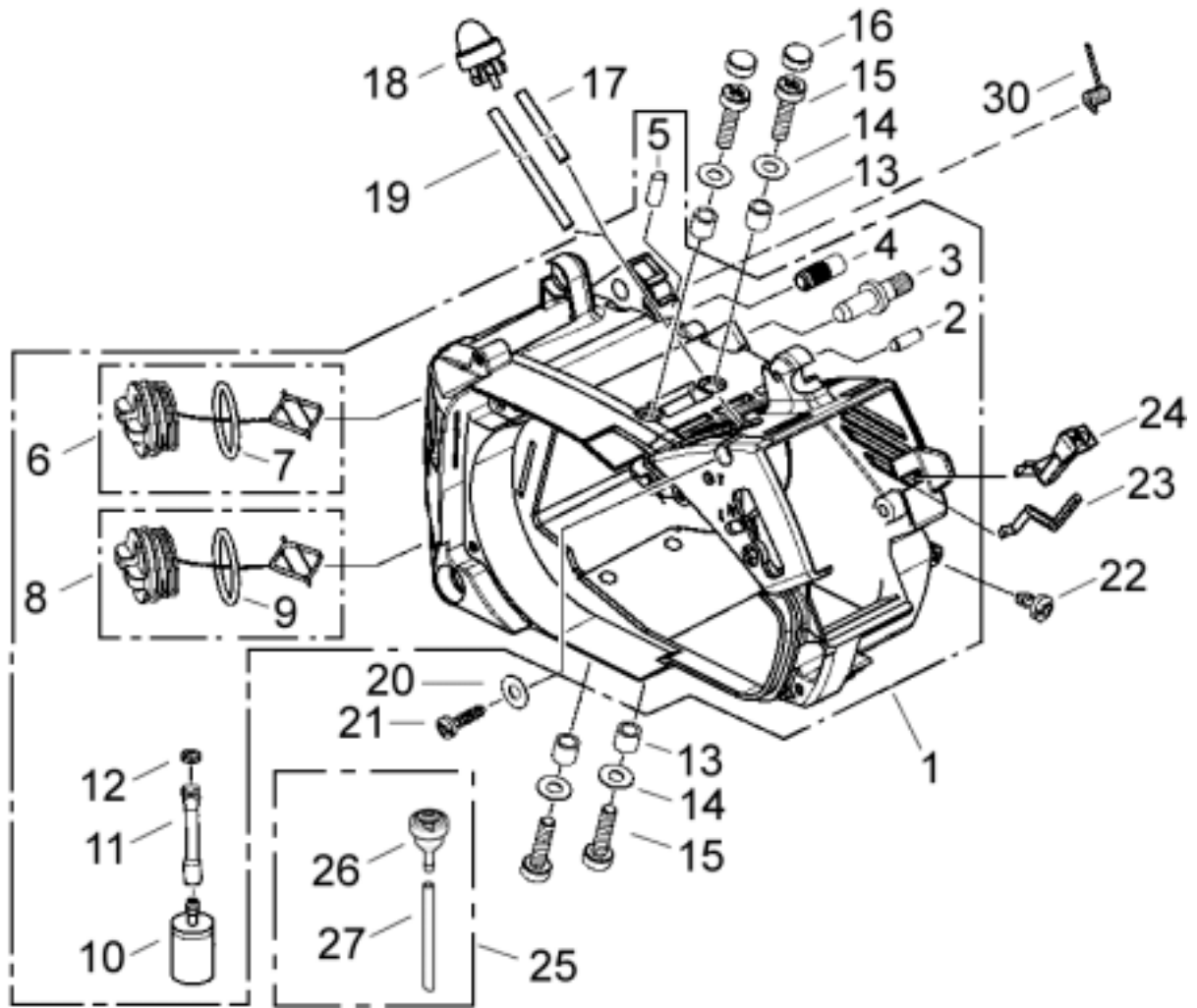

Bild-Nr. Pos.-No. No.Pos. Pos.-No.	Bestell-Nr. Order-No. No. de Cde Ref.-Nr.	Menge Quantity Nombres Cantidad	Starter	Starter	Lanceur	Arranque
1	26 00 322	1	Starter, kompl. enth. (-> 1 - 10)	Starter, compl. incl. (->1 - 10)	Lanceur, compl. y inclus (->1 - 10)	Arranque, compl. incl. (->1 - 10)
2	00 69 889	1	SKS "SOLO"	Decal "SOLO"	Autocollant "SOLO"	Etiqueta "SOLO"
3	21 00 891	1	Startergehäuse	Starter housing	Boîtier starter	Caja de arranque
4	00 63 170 25	1	Starterseil 3x850	Starter rope	Corde de lanceur	Cuerda de arranque
5	20 74 403 25	1	Startergriff	Starter grip	Poignée lanceur	Empunadura arranque
6	26 00 283	1	Federkassette	Spring cassette	Cassette de ressort	Caja de resorte
7	20 74 992	1	Seilrolle	Rope pulley	Poulie	Roldana
8	20 74 135	1	Starterklinke	Starter pawl	Cliquet de starter	Trinquete
9	20 74 136	1	Kulisse	Template	Coulisse	Colisa
10	00 73 417	1	Federstecker 1,4 <-)	Spring plug <-)	Cosse de ressort <-)	Enchufe <-)
11	00 18 363	3	Linsschraube 5x20	Screw	Vis	Tornillo

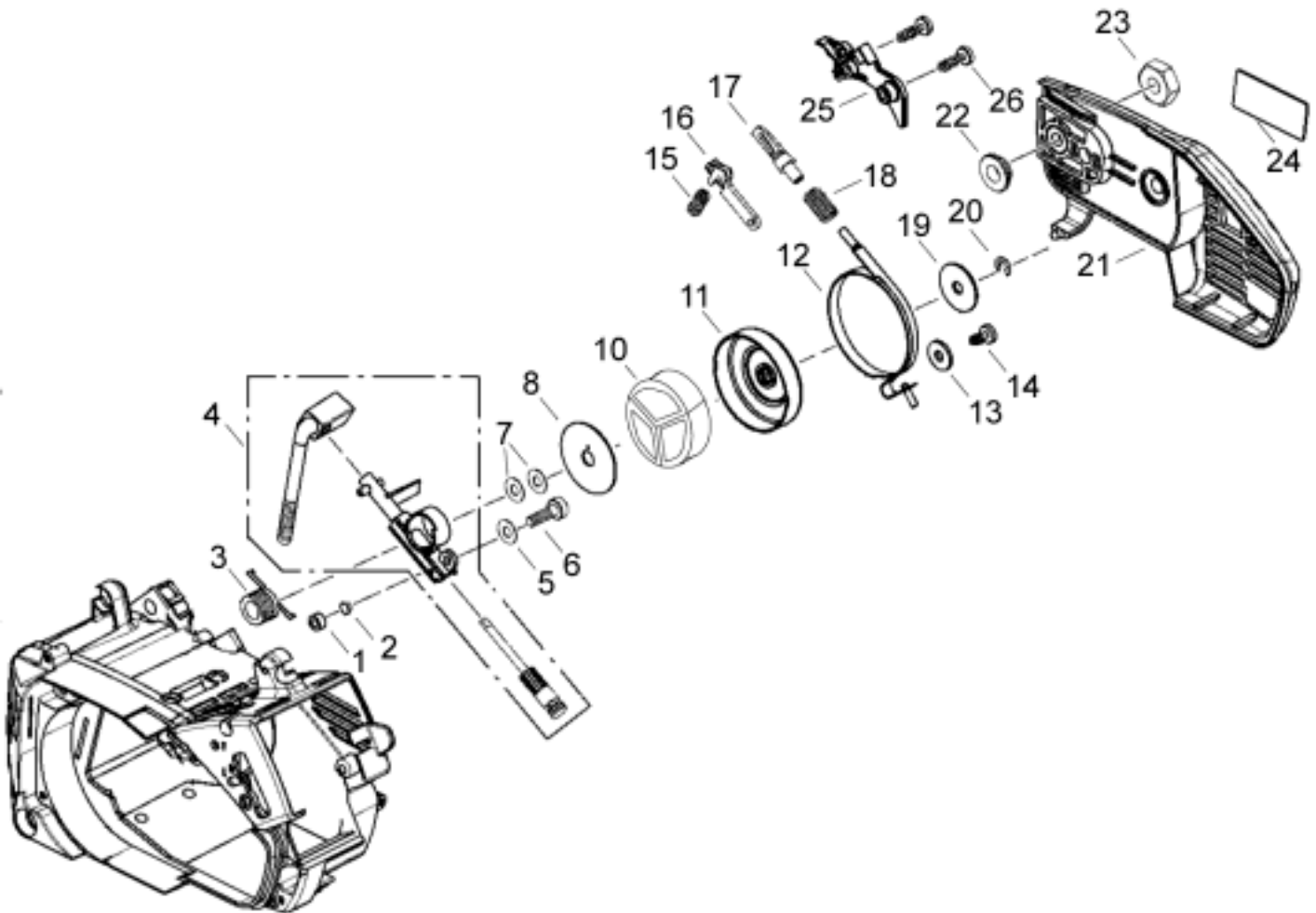

Bild-Nr. Pos.-No. No.Pos. Pos.-No.	Bestell-Nr. Order-No. No. de Cde Ref.-Nr.	Menge Quantity Nombres Cantidad	Bügel / Handgriff	Handle bar	Etrier	Asa
2	00 18 361	2	Linsenschraube 5x12	Screw	Vis	Tornillo
3	00 73 397	3	Dämpfungsfeder 2,5x13,5x33 mm	Spring	Ressort amortisseur	Resorte
4	60 73 141	1	Haltebügel	Handle bar	Étrier	Empunadura
5	00 18 363	2	Linsenschraube 5x20	Screw	Vis	Tornillo
6	60 73 975	1	Griffschale links	Grip cup left	Couvercle de poignée q.	Cascara izqu.
7	60 74 113	1	Umlenkhebel	Lever	Levier	Palanca
8	20 36 133	1	Gasgestänge	Throttle linkage	Tringle	Varilla de gas
9	00 73 101	1	Schenkelfeder 8x15 mm	Spring	Ressort	Resorte
10	60 74 114	1	Sicherungshebel	Safety lever	Levier de sécurité	Palanca seguridad
13	00 18 382	1	Linsenschraube 5x55 mm	Screw	Vis	Tornillo
15	00 18 371	1	Linsenschraube 6x25 mm	Screw	Vis	Tornillo
16	00 84 867	1	Kabel; Masse und Kurzschluss	Cable; ground + shortcircuit	Câbles masse + court-circuit	Cable; de masa + interruptor
17	00 84 888	1	Kurzschlusschalter	Short circuit switch	Interrupteur	Interruptor
20	00 18 361	1	Linsenschraube 5x12 mm	Screw	Vis	Tornillo
21	00 18 274	1	Linsenschraube 5x16 mm	Screw	Vis	Tornillo
22	00 18 276	1	Linsenschraube 5x35 mm	Screw	Vis	Tornillo
23	60 74 130	3	Hülse	Sleeve	Douille	Casquillo
25	00 18 363	1	Linsenschraube 5x20	Screw	Vis	Tornillo
27	00 33 231	1	Distanzrohr 10x2,3x10	Spacer tube	Entretoise	Tubo distanciador
28	60 73 105 25	1	Handschutz	Hand protection	Protection	Proteccion de mano
29	60 32 690	1	Sechskant-Schraube M4x21,5 mm	Screw	Vis	Tornillo
30	00 28 118	1	6-kt. Mutter M4	Nut	Écrou	Tuerca
31	00 33 230	1	Distanzrohr 10x2,3x16,3	Spacer tube	Entretoise	Tubo distanciador
32	00 72 140	2	Scheibe 5,2x12x0,5	Washer	Rondelle	Arandela
33	00 18 257	1	Linsenschraube 5x25	Screw	Vis	Tornillo
35	00 98 140	1	Fangsicke	Safety device	Bandelette retenue	Seguridad
36	00 30 108	1	Scheibe 5,3 mm	Washer	Rondelle	Arandela
37	00 18 362	1	Linsenschraube 5x10 mm	Screw	Vis	Tornillo
40	68 00 862	1	Griff rechts enth. (-> 40 - 44)	Handle right incl. (-> 40 - 44)	Poignée droite y inclus (-> 40 - 44)	Empunadura derecha incl. (-> 40 - 44)
41	60 74 115	1	Gashebel	Gas lever	Levier des gaz	Palanca de gas
42	60 73 976	1	Griffschale rechts	Grip cup right	Couvercle de poignée dr.	Cascara der.
44	00 35 160	1	Sicherungsscheibe 7x13,5x1,4 (->)	Washer (->)	Rondelle (->)	Arandela (->)

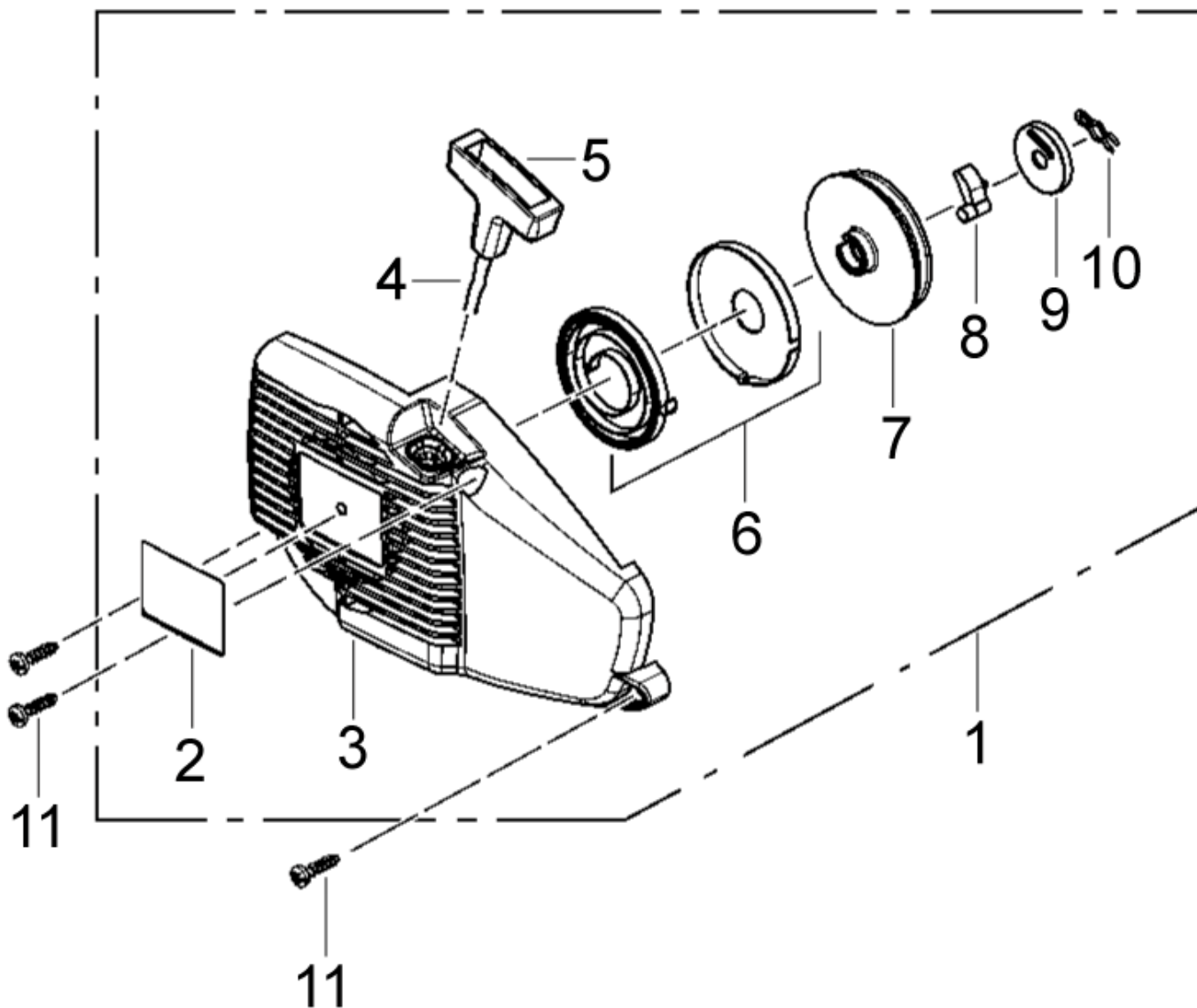

Bild-Nr. Pos.-No. No.Pos. Pos.-No.	Bestell-Nr. Order-No. No. de Cde Ref.-Nr.	Menge Quantity Nombres Cantidad	Schwert, Kette, Anschlagkralle	Guide bar, chain, bucking spike	Guide chaîne, chaîne, griffe de butée	Espada, cadena, garra de apoyo
1	69 00 1362	1	Kette 3/8S"; 1,3; 52E; 14"; 35 cm enth. (-> 1 - 7	Chain incl. (-> 1 - 7	Chaîne y inclus (-> 1 - 7	Cadena incl. (-> 1 - 7
2	05 40 197	1	Linksschneider	Left cutter	Couteau gauche	Cortador izquierda
3	05 40 198	1	Rechtsschneider	Right cutter	Couteau droite	Cortador derecha
4	05 40 199	1	Verbindungsglied ohne Niet	Connect. Link w/o rivet	Maillon sans rivet	Union
5	05 40 200	1	Verbindungsglied mit Niet	Connect. Link with rivet	Maillon avec rivet	Union
6	05 40 201	1	Treibglied	Drive link	Maillon entraineur	Eslabon de mango
7	05 40 202	1	Niet <-)	Rivet <-)	Rivet <-)	Remache <-)
10	00 18 420	1	Spannschraube	Screw	Vis	Tornillo
11	00 55 101	1	Sicherungsscheibe 4	Tension washer	Rondelle de tension	Arandela elastica
12	60 32 640	1	Kettenspannbolzen	Chain tension bolt	Tendeur de chaîne	Perno de fijación de cad.
13	69 00 7442	1	Schwert, 35 cm (14")	Guide bar	Guide chaîne	Espada
14	60 71 244	1	Kettenschutz	Chainguard	Protect. Chaîne	Protect. Cadena
15	60 43 323	1	Anschlagkralle	Bucking spike	Griffe de butée	Garra de apoyo
16	00 18 362	2	Linsenschraube 5x10 mm	Screw	Vis	Tornillo

Werkzeug, Zubehör (optional) / Tools, accessories (optional)/

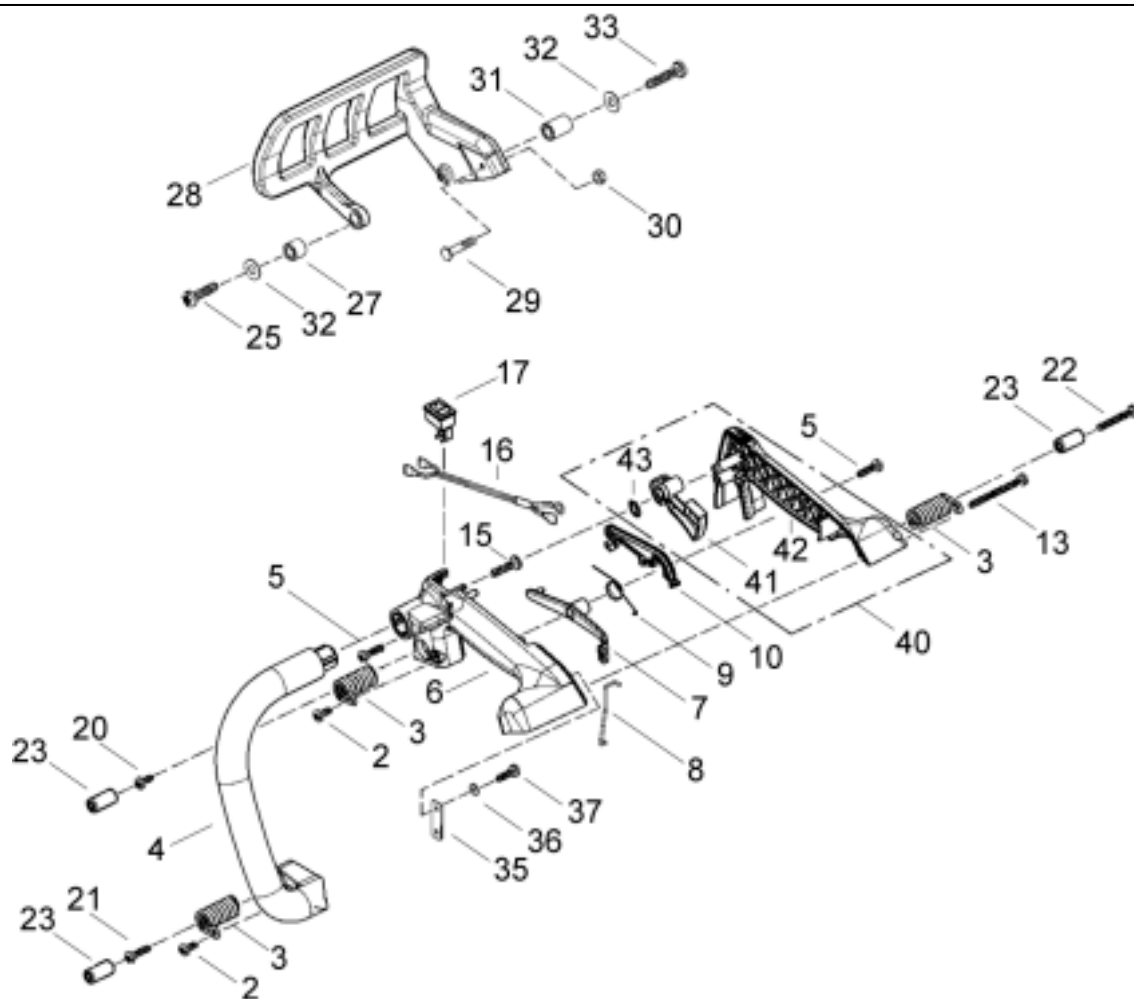
Outils, accessoires (optionnel) / Herramientas, accesorios (opcionales)

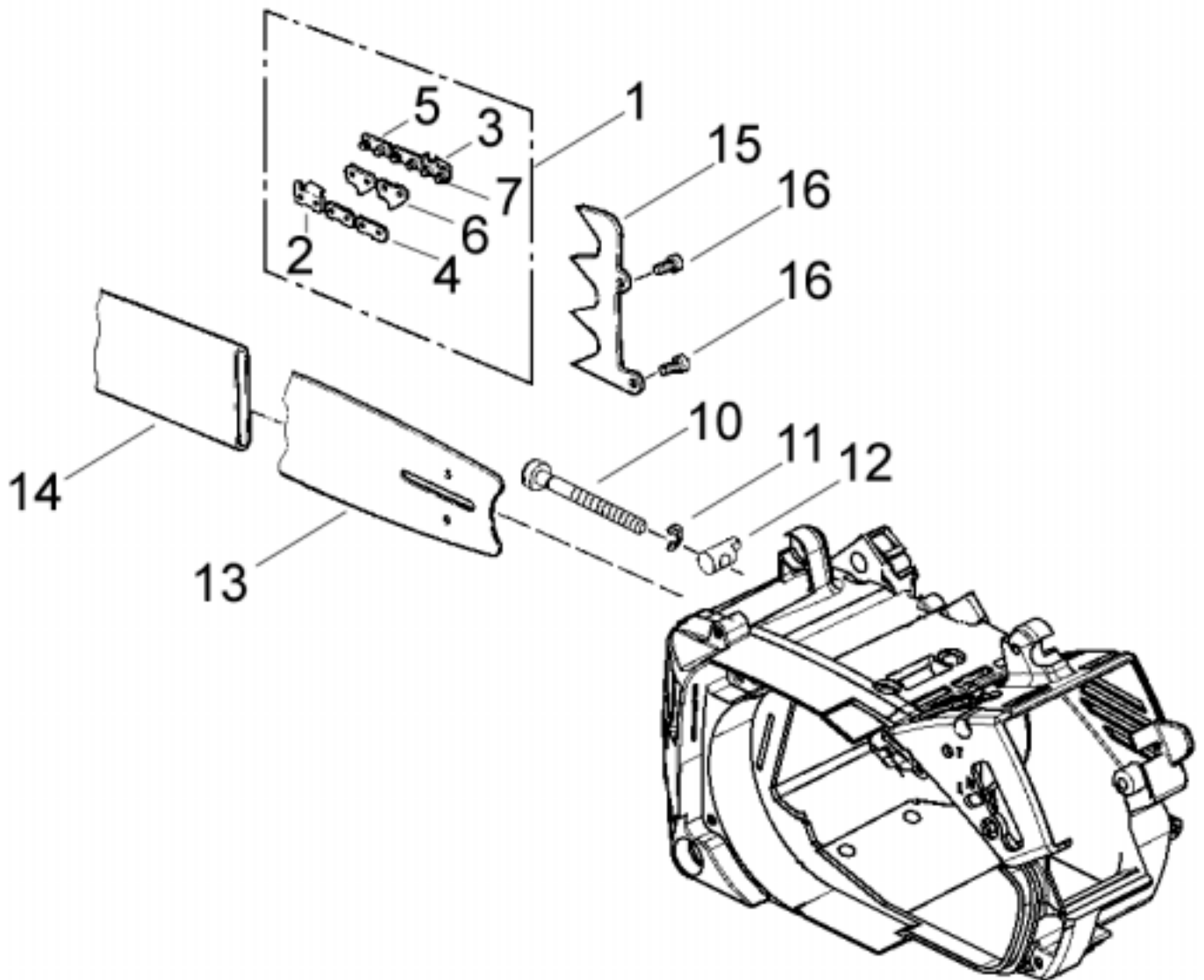

Bild-Nr. Pos.-No. No.Pos. Pos.-No.	Bestell-Nr. Order-No. No. de Cde Ref.-Nr.	Menge Quantity Nombres Cantidad	Werkzeug, Zubehör (optional)	Tools, accessories (optional)	Outillage, accesories (optional)	Herramientas, accesorios (opcionale)
1	00 80 489	1	Kombischlüssel 19	Combi wrench	Clef universelle	Llave
4	00 80 574	1	Montageschlüssel f. Kupplung	Montageschlüssel f. Kupplung	Montageschlüssel f. Kupplung	Montageschlüssel f. Kupplung
5	69 00 133	1	Schwert, 30 cm (12'')	Guide bar, 30 cm (12'')	Guide chaîne, 30 cm (12'')	Espada, 30 cm (12'')
6	69 00 136	1	Kette 3/8S"; 1,3; 45E; 12" ; 30 cm	Chain 3/8S"; 1,3; 45E; 12" ; 30 cm	Chaîne 3/8S"; 1,3; 45E; 12" ; 30 cm	Cadena 3/8S"; 1,3; 45E; 12" ; 30 cm
11	00 83 135	1 Liter	Zweitakt-Spezialöl CASTROL-Super TT	Special 2-stroke oil CASTROL-Super TT	Huile spéciale 2 temps CASTROL-Super TT	Aceite especial para motores de 2 tiempos
12	00 83 150	1 Liter	Sägenketten-Haftöl	Chain oil	Huile d'adhésion de la chaîne	Aceite adhesivo para cadenas
12	00 83 118	5 Liter	Sägenketten-Haftöl	Chain oil	Huile d'adhésion de la chaîne	Aceite adhesivo para cadenas
12	00 83 120	20 Liter	Sägenketten-Haftöl	Chain oil	Huile d'adhésion de la chaîne	Aceite adhesivo para cadenas
12	00 83 121	60 Liter	Sägenketten-Haftöl	Chain oil	Huile d'adhésion de la chaîne	Aceite adhesivo para cadenas
12	00 83 158	210 Liter	Sägenketten-Haftöl	Chain oil	Huile d'adhésion de la chaîne	Aceite adhesivo para cadenas
13	00 83 153	1 Liter	Biologisch abbaubares Sägeketten-Haftöl	Bio-degradable bar & chain oil	Huile d'adhésion de la chaîne Bio-dégradable	Aceite biologicamente reductible para cadenas
13	00 83 148	5 Liter	Biologisch abbaubares Sägeketten-Haftöl	Bio-degradable bar & chain oil	Huile d'adhésion de la chaîne Bio-dégradable	Aceite biologicamente reductible para cadenas
13	00 83 149	20 Liter	Biologisch abbaubares Sägeketten-Haftöl	Bio-degradable bar & chain oil	Huile d'adhésion de la chaîne Bio-dégradable	Aceite biologicamente reductible para cadenas
13	00 83 157	60 Liter	Biologisch abbaubares Sägeketten-Haftöl	Bio-degradable bar & chain oil	Huile d'adhésion de la chaîne Bio-dégradable	Aceite biologicamente reductible para cadenas
13	00 83 156	210 Liter	Biologisch abbaubares Sägeketten-Haftöl	Bio-degradable bar & chain oil	Huile d'adhésion de la chaîne Bio-dégradable	Aceite biologicamente reductible para cadenas
14	60 00 206	1	Elektro- Kettenschärfgerät	Electric chain sharpener	Affûteuse électrique	Afilador electrico de cadenas
15	60 00 200	1	Handfeilgerät ohne Feile	Manual file guide (without file)	Affûteuse à main (sans lime)	Afilador manual (sin lima)
16	60 00 207	1	Entnietgerät	Chain rivet breaker	Dériveteuse	Desremachador de cadenas
17	60 00 208	1	Vernietgerät	Riveter	Riveteuse	Remachador de cadenas
18	00 80 358	1	Sägeketten-Rundfeile Ø 4 mm ohne Heft	Round file for chain saws	Limes rondes	Lima redonda
19	00 80 108	1	Feilenheft	File wallet	Support de limes	Mango de lima
20	00 80 447	1	Feilenhalter mit Feile Ø 4 mm	File holder	Manches à limes	Portalimas
21	00 80 430	1	Fettpresse	Grease gun	Pompe à graisse	Prensa de grasa
22	27 00 278	1	Mixbehälter 1 Liter	Mixing can 1 liter	Jerrycan 1 litre	Bidon de mezcla 1 litro
25	69 00 791	1	Transportbox für Sägen	Chain saw carry case	Box de transport pour tronçonneuses	Caja de transporte para motosierras
26	99 39 011 00	1	Schutzhelm	Safety helmet	Casque de protection	Casco protector
27	99 39 010 01	1	Gesichts / Gehör- schutzkombination	Gesichts / Gehör- schutzkombination	Gesichts / Gehörschutzkombination	Gesichts / Gehörschutzkombination

Bestell-Nr. Order-No. No. de Cde Ref.-Nr.	Menge Quantity Nombres Cantidad	Seite Page Page Pagina
00 18 110	2	3
00 18 226	2	3
00 18 257	1	7
00 18 274	3	3
00 18 274	2	5
00 18 274	1	7
00 18 276	1	7
00 18 327	2	2
00 18 336	1	4
00 18 340	4	2
00 18 361	2	7
00 18 361	1	7
00 18 362	1	5
00 18 362	1	7
00 18 362	2	8
00 18 363	1	5
00 18 363	3	6
00 18 363	2	7
00 18 363	1	7
00 18 371	1	7
00 18 380	1	4
00 18 382	1	7
00 18 399	1	3
00 18 420	1	8
00 18 423	4	4
00 20 145	1	2
00 20 214	1	5
00 28 118	1	7
00 28 137	2	3
00 30 101	1	2
00 30 102	1	5
00 30 108	1	4
00 30 108	1	5
00 30 108	1	7
00 31 194	1	2
00 31 625	2	5
00 31 626	1	5
00 33 230	1	7
00 33 231	1	7
00 33 268 25	4	4
00 35 160	1	7
00 40 188	1	4
00 41 104	1	4
00 44 130	1	5
00 54 237	2	2
00 55 101	1	8
00 55 134	1	2
00 55 216	1	5
00 55 226	1	2

Bestell-Nr. Order-No. No. de Cde Ref.-Nr.	Menge Quantity Nombres Cantidad	Seite Page Page Pagina
00 55 278	2	2
00 60 120	1	3
00 61 130	1	2
00 62 146	1	4
00 62 147	1	4
00 62 280	2	2
00 63 170 25	1	6
00 64 300	1	3
00 64 319	1	3
00 64 407	1	4
00 64 440	1	4
00 64 441	1	4
00 66 381	1	3
00 66 455	1	2
00 69 106	1	5
00 69 767	1	3
00 69 889	1	6
00 70 253	1	5
00 70 254	1	5
00 71 153	2	3
00 72 140	4	2
00 72 140	4	4
00 72 140	2	7
00 72 141	1	2
00 72 144	6	3
00 72 148	2	2
00 73 101	0	7
00 73 352	1	4
00 73 360	1	2
00 73 381	1	4
00 73 397	3	7
00 73 417	1	6
00 80 108	1	9
00 80 358	1	9
00 80 430	1	9
00 80 447	1	9
00 80 489	1	9
00 80 574	1	9
00 83 118	5 Liter	9
00 83 120	20 Liter	9
00 83 121	60 Liter	9
00 83 135	1 Liter	9
00 83 148	5 Liter	9
00 83 149	20 Liter	9
00 83 150	1 Liter	9
00 83 153	1 Liter	9
00 83 156	210 Liter	9
00 83 157	60 Liter	9
00 83 158	210 Liter	9

Bestell-Nr. Order-No. No. de Cde Ref.-Nr.	Menge Quantity Nombres Cantidad	Seite Page Page Pagina
00 84 621	1	2
00 84 867	1	7
00 84 888	1	7
00 98 140	1	7
05 10 984	1	3
05 10 985	1	3
05 10 986	1	3
05 10 987	1	3
05 40 197	1	8
05 40 198	1	8
05 40 199	1	8
05 40 200	1	8
05 40 201	1	8
05 40 202	1	8
20 31 117 25	1	2
20 36 133	1	7
20 48 140	1	2
20 48 389	1	3
20 48 390	1	3
20 61 514	1	3
20 61 516	1	3
20 63 212	1	4
20 63 370	2	2
20 74 135	1	6
20 74 136	1	6
20 74 403 25	1	6
20 74 905	1	3
20 74 992	1	6
21 00 240	1	2
21 00 364 25	2	2
21 00 891	1	6
22 00 153	1	2
22 00 243 52	1	2
22 00 987	1	2
23 00 138 10	1	3
23 00 481	1	2
23 00 730	1	2
23 00 815	1	3
24 00 278	1	2
25 00 209	1	3
25 00 814	1	3
26 00 283	1	6
26 00 322	1	6
27 00 278	1	9
27 00 322	1	4
27 00 326	1	4
27 00 348	1	4
27 00 403		
27 00 416	1	4

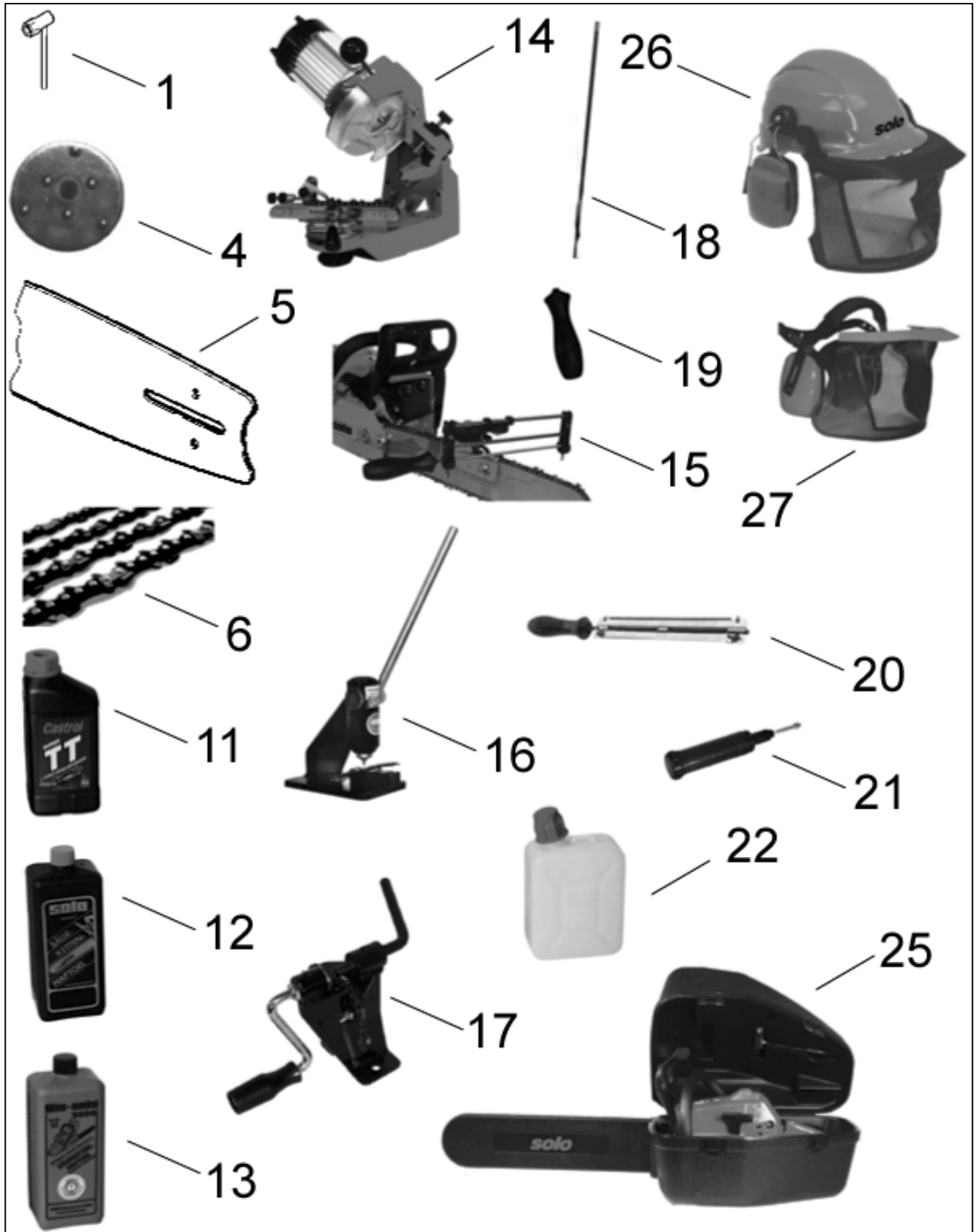
Bestell-Nr. Order-No. No. de Cde Ref.-Nr.	Menge Quantity Nombres Cantidad	Seite Page Page Pagina
27 00 426	1	4
27 00 430	1	4
35 00 433 25	1	5
35 00 460	1	5
50 74 562	1	4
60 00 200	1	9
60 00 206	1	9
60 00 207	1	9
60 00 208	1	9
60 31 993	1	5
60 32 640	1	8
60 32 690	1	7
60 42 631	1	5
60 43 323	1	8
60 63 101	1	3
60 71 244	1	8
60 73 105 25	1	7
60 73 141	1	7
60 73 975	1	7
60 73 976	1	7
60 74 113	1	7
60 74 114	1	7
60 74 115	1	7
60 74 116	1	3
60 74 120	1	5
60 74 121	2	4
60 74 130	3	7
60 74 136	1	4
60 74 137	1	4
60 74 636	1	3
60 74 650	1	5
60 74 975	1	5
61 00 134	1	2
61 00 135	1	4
61 00 427	1	5
62 00 134 25	1	5
63 00 175 25	1	5
63 00 208 25	1	5
64 00 106	1	5
68 00 334 25	1	3
68 00 862	1	7
69 00 133	1	9
69 00 136	1	9
69 00 1362	1	8
69 00 7442	1	8
69 00 791	1	9
99 39 010 01	1	9
99 39 011 00	1	9

D**Allgemeine Richtlinien für die Bestellung von Original SOLO Ersatzteilen:**

Voraussetzung für eine reibungslose Erledigung sind folgende Angaben:

1. Ersatzteil-Bestellnummer
2. Gewünschte Anzahl
3. Typenbezeichnung des Geräts

Diese Ersatzteilliste ist für die Lieferung und Ausstattung von SOLO Erzeugnissen unverbindlich.

Im Interesse der technischen Weiterentwicklung bleiben Konstruktionsänderungen vorbehalten.

GB**General Directions for Ordering Original SOLO Spare Parts:**

For correct and diligent processing of your order, please give the following information:

1. Spare Part number
2. Quantity
3. Model and serial number
4. Shipping instructions

Delivery is made in accordance with our general sales and delivery conditions. This spare parts list is non-committal for us with regard to delivery and layout of SOLO products. In favour of technical improvements, design modifications are subject to change without notice.

F**Directives générales pour les commandes de pièces de rechange d'origine SOLO:**

Il est indispensable de préciser dans toutes les commandes de pièces:

1. le numéro de référence de la pièce
2. la quantité
3. le type de la machine
4. le mode d'expédition

Les livraisons sont effectuées dans le cadre de nos conditions générales de vente. Toutes modifications réservées.

E**Directivas Generales de pedido de la firma SOLO:**

Por adelantado de un arreglo sin dificultades necesitamos siguientes indicaciones:

1. Número de repuesto
2. Numero de cantidad
3. Modelo y número de serial
4. Instrucción de Envío

Esta lista de repuestos no es obligatoria para los envíos y/o forma de equipo de los productos SOLO.

En el interés del constante desarrollo debemos reservarnos el derecho de cambios.