

Ersatzteilliste  
Spare parts list

Liste de pièces de rechange

Lista de piezas de recambio

Motor-Sprühgerät Port 423 / Port 423 S

Gasoline powered mist blower

Atomiseur à moteur

Atomizador

MADE  
BY  
SOLO

MADE IN GERMANY

D 9 423 748 - 09/01

### Zeichenerklärung Legend

→XXXXX Bis Serien-Nr.  
XXXXX→ Ab Serien-Nr.  
+ Neues Teil gegenüber D 9 423 745  
\*+ Neues Teil gegenüber D 9 423 745,  
mit Bezug auf Serien-Nr.  
a Neues Teil gegenüber D 9 423 747  
\*a Neues Teil gegenüber D 9 423 747,  
mit Bezug auf Serien-Nr.

up to serial no.  
as of serial no.  
new part compared to D 9 423 745  
new part compared to D 9 423 745,  
referring to serial no.  
new part compared to D 9 423 747  
new part compared to D 9 423 747,  
referring to serial no.

### Légende

jusqu'au no. de série  
à partir de no. de série  
nouvelle pièce par rapport à D 9 423 745  
nouvelle pièce par rapport à D 9 423 745,  
se référant au no. de série  
nouvelle pièce par rapport à D 9 423 747  
nouvelle pièce par rapport à D 9 423 747,  
se référant au no. de série

### Leyenda

hasta no. de serie  
desde de no. de serie  
parte nuevo comparado con D 9 423 745  
parte nuevo comparado con D 9 423 745,  
referente al no. de serie  
parte nuevo comparado con D 9 423 747  
parte nuevo comparado con D 9 423 747,  
referente al no. de serie

**solo**<sup>®</sup>

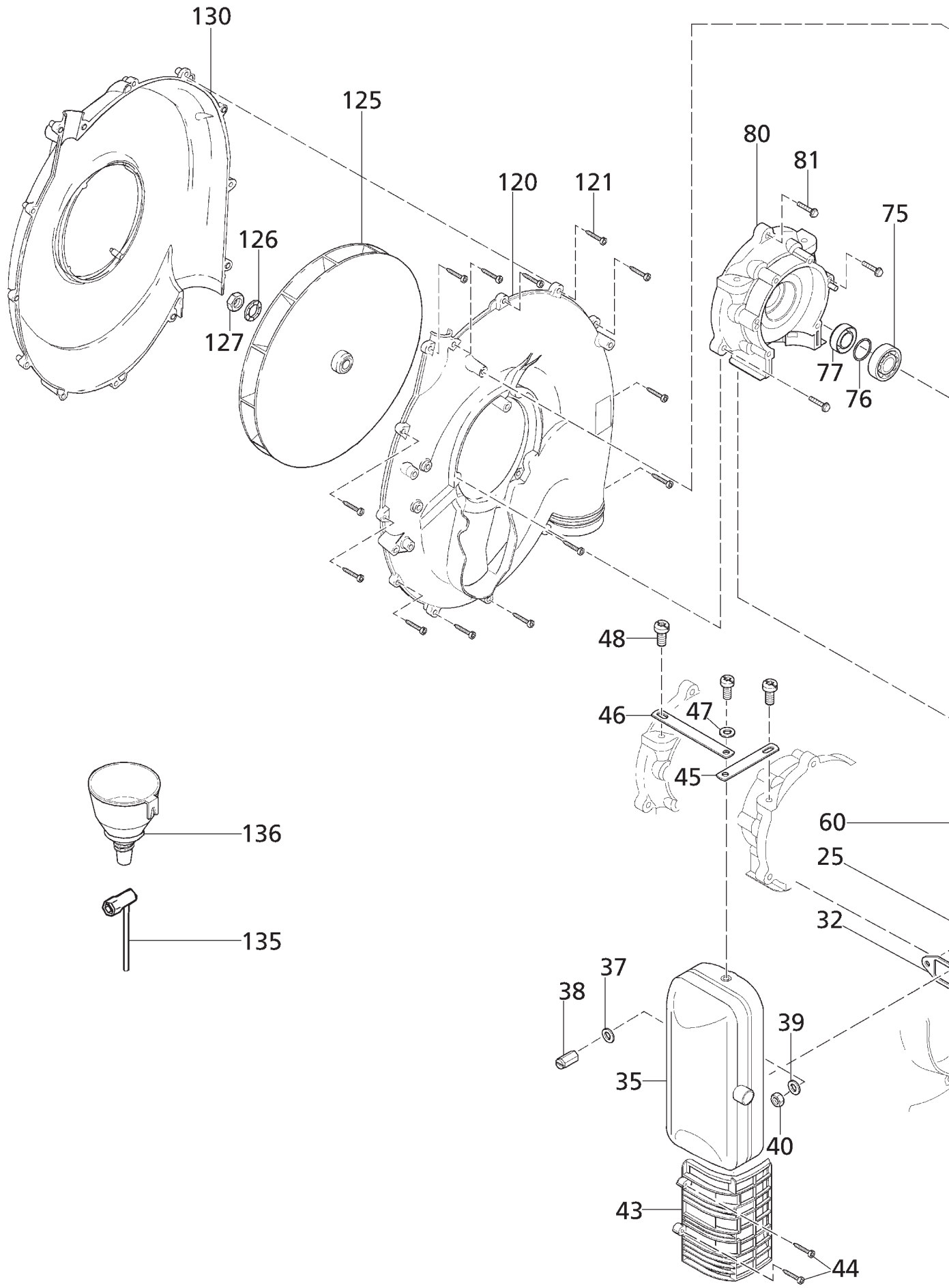

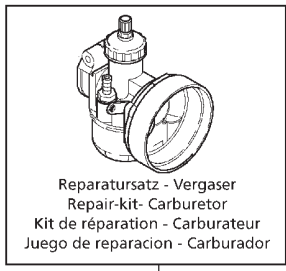
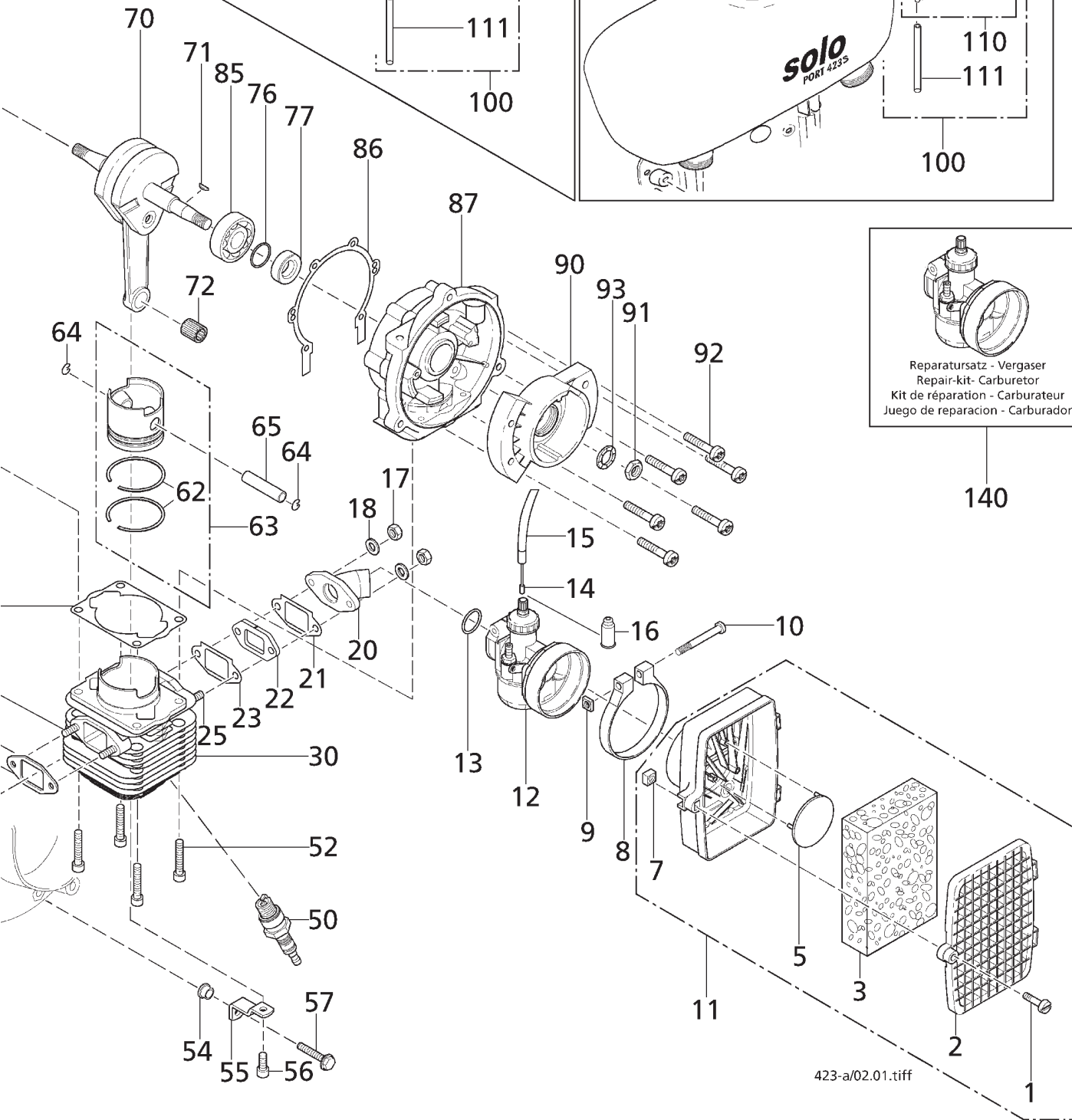
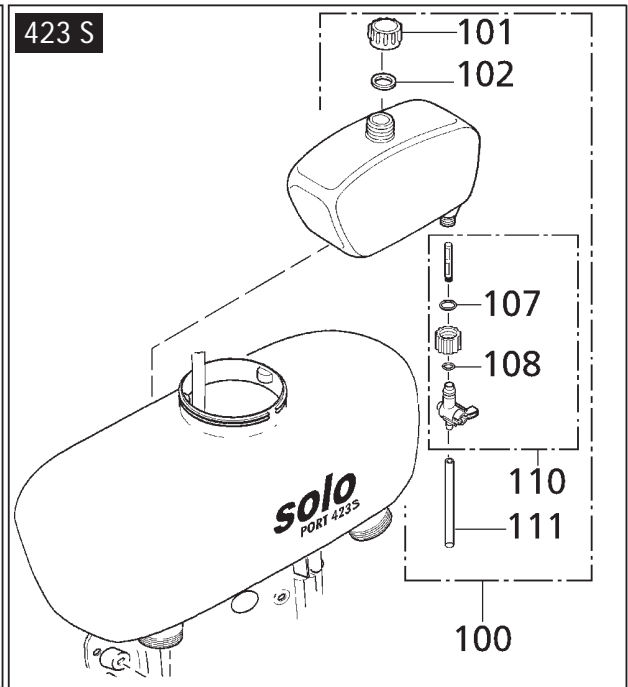
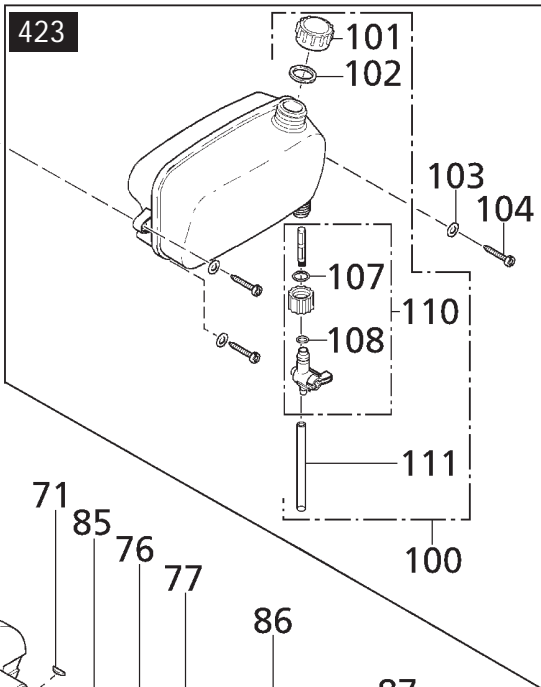

Reparaturatz - Vergaser  
 Repair-kit- Carburetor  
 Kit de réparation - Carburateur  
 Juego de reparación - Carburador

140

423-a/02.01.tiff

Bild-Nr. Pos.-No. Pos.-No. Pos.-No.	Bestell-Nr. Order-No. No. de Cde. Ref.-Nr.	Modell Type Modèle Modelo	Menge Quantity Nombres Cantidad	Motor/ Gebläse	Engine/ Blower Housing	Moteur/ Carter de Turbine	Motor/ Caja del Ventilador
1	00 10 557		1	Schraube M6x25 DIN 85 B	screw	vis	tornillo
2	20 73 500		1	Filterdeckel	filter cover	couvercle du filtre	tapa del filtro
3	20 48 348		1	Filtereinsatz	filter element	filtre à air	filtro
5	20 74 252		1	Scheibe 43x48x2	washer	rondelle	disco
7	00 20 142		1	Vierkantmutter M6 DIN 557	nut	écrou	tuerca
8	00 66 399		1	Schelle 68x10	clamp	collier	abrazadera
9	00 20 160		1	Vierkantmutter M6 DIN 557	nut	écrou	tuerca
10	00 11 274		1	Zylinderschraube M5x50/30	screw	vis	tornillo cilíndrico
11	25 00 570		1	Luftfilter, kompl.(enth.:	air filter, compl.(incl.:	filtre à air, compl.(incl.:	filtro de aire, compl.(incl.:
(1)	00 10 557		1	Schraube M6x25 DIN 85 B	screw	vis	tornillo
(2)	20 73 500		1	Filterdeckel	filter cover	couvercle du filtre	tapa del filtro
(3)	20 48 348		1	Filtereinsatz	filter element	filtre à air	filtro
(5)	20 74 252		1	Scheibe 43x48x2	washer	rondelle	disco
(7)	00 20 142		1	Vierkantmutter M6 DIN 557)	nut)	écrou)	tuerca)
12	23 00 558	423	1	Vergaser Bing 1/15/110	carburetor, compl.	carburateur, compl.	carburador, compl.
12	23 00 700	423 S	1	Vergaser Bing 1/15/110 A	carburetor, compl.	carburateur, compl.	carburador, compl.
13	00 62 235		1	O-Ring 20x1,5	ring	joint bague	anillo
14	28 00 559		1	Bowdenzug Gas 1x1193	bowden cable gas	transmission de gaz	cable de bowden
16	00 66 111 a		1	Schutzkappe	port cap	capuchon	gomas
15	00 64 363		1	Schlauch 6x1	hose	tuyau	tubo
17	00 20 102		2	Sechskantmutter M6 DIN 934	nut	écrou	tuerca
18	00 34 107		2	Federscheibe 6 DIN 137 B	spring washer	rondelle élastique	arandela de resorte
20	20 12 140	423 S	1	Vergaserkrümmer	carburetor elbow	pipe d'aspiration	codo del carburador
20	20 12 815 *a	423	1	Vergaserkrümmer	carburetor elbow	pipe d'aspiration	codo del carburador
21	20 61 336	423 S	1	Vergaserdichtung 0,5 mm dick	carburetor gasket	joint d'admission	junta del carburador
21	20 61 127 *a	423	2	Vergaserdichtung 0,5 mm dick	carburetor gasket	joint d'admission	junta del carburador
22	20 74 616	423 S	1	Isolierflansch	carburetor port piece	bride d'admission	apoyo del carburador
22	20 74 196 *a	423	1	Isolierflansch	carburetor port piece	bride d'admission	apoyo del carburador
23	20 61 127		1	Vergaserdichtung 0,5 mm dick	carburetor gasket	joint d'admission	junta del carburador
25	00 15 209		4	Stiftschraube M6x18 DIN 940	stud	vis	tornillo
30	22 00 946 *a	423	1	Buchsenzylinder Ø 48,00 mm	sleeved cylinder	cylindre chemisé	cilindro
30	22 00 935 *a	423 S	1	Buchsenzylinder Ø 48,00 mm	sleeved cylinder	cylindre chemisé	cilindro
32	20 61 140		1	Auspuffdichtung 1,5 mm dick	muffler gasket	joint d'échappement	junta del escape
35	25 00 351	423	1	Blechauspuff, kompl.	muffler, compl.	échappement, compl.	escape, compl.
35	25 00 354	423 S	1	Blechauspuff, kompl.	muffler, compl.	échappement, compl.	escape, compl.
37	00 34 114		1	Federring 6 DIN 128 A	spring ring	rondelle élastique	anillo elastico
38	00 21 100		1	Sechskantmutter M6	nut	écrou	tuerca
39	00 34 114		1	Federring 6 DIN 128 A	spring ring	rondelle élastique	anillo elastico
40	00 20 102		1	Sechskantmutter M6 DIN 934	nut	écrou	tuerca
43	20 73 455		1	Auspuffschutz	exhaust protection	protection de l'échappement	proteccion del escape
44	00 18 257		2	Linenschraube 5x25	screw	vis	tornillo
45	20 23 367		1	Auspuffstrebe 12x260,5/79,5	muffler brace	tirant d'échappement	tirante del escape
46	20 23 366		1	Auspuffstrebe 12x2x87/105	muffler brace	tirant d'échappement	tirante del escape
47	00 34 114		1	Federring 6 DIN 128 A	spring ring	rondelle élastique	anillo elastico
48	00 18 345		3	Zylinderschraube M6x12	screw	vis	tornillo cilíndrico
50	23 00 106		1	Zündkerze W 8AC	spark plug	bougie	bujia
52	00 18 348		4	Zylinderschraube M6x25	screw	vis	tornillo cilíndrico
54	40 74 352		1	Schutzkappe	protector cap	recouvrement	tapa
55	20 43 338	423	1	Befestigungswinkel	brace	tirant	tirante
55	20 43 411	423 S	1	Befestigungswinkel	brace	tirant	tirante
56	00 18 345		1	Zylinderschraube M6x12	screw	vis	tornillo cilíndrico
57	00 18 345		1	Zylinderschraube M6x12	screw	vis	tornillo cilíndrico
60	20 61 113		1	Zylinderdichtung 0,5 mm dick	cylinder gasket	joint de cylindre	junta del cilindro
62	20 48 116	423 / S	2	Kolbenring 48x2	piston ring	segment	segmento del piston
62	20 48 255	423 Ü	2	Kolbenring 48,5x2	piston ring	segment	segmento del piston
63	22 00 111	423 / S	1	Kolben Ø 48,0 mm,(enth.:	piston (incl.:	piston (incl.:	piston (incl.:
(62)	20 48 116	423 / S	2	Kolbenring 48x2)	piston ring)	segment)	segmento del piston)
63	22 00 241	423 Ü	1	Kolben Ø 48,5 mm,(enth.:	piston (incl.:	piston (incl.:	piston (incl.:
(62)	20 48 255	423 Ü	2	Kolbenring 48,5x2)	piston ring)	segment)	segmento del piston)
64	00 55 122		2	Kolbenbolzensicherungsring 12x1	piston check pin	arrêt d'axe de piston	seguro
65	20 31 168 25		1	Kolbenbolzen 12/8x40	piston pin	axe de piston	bulon de piston
70	22 00 628		1	Kurbelwelle, kompl.	crankshaft, compl.	vilebrequin, compl.	cigüal, compl.
71	00 75 100		1	Scheibenfeder 2x3,7 DIN 6888	woodruff key	clavette	chaveta de disco
72	00 52 205		1	Nadelkäfig 12x15x17,5	needle bearing	roulement à aiguilles	casquillo cojinete
75	00 50 125		1	Rillenkugellager 15x42x13 DIN 6302	ball bearing	roulement à billes	cojinete de bolas
76	00 31 375		2	Anlaufscheibe 15,3x22x0,5	washer	rondelle	disco
77	00 54 133		2	Wellendichtung 15x26x7 DIN 3760 B	oil seal	joint d'arbre	empaquetadura del árbol
80	21 00 311		1	Kurbelgehäuse, Abtriebsseite	crankcase, drive side	carter moteur côté turbine	caja del cigüal p.d. sacado
81	00 12 368		3	Sechskantschraube M6x20	screw	vis	tornillo
85	00 50 102		1	Rillenkugellager 15x35x11 DIN 6202 C	ball bearing	roulement à billes	cojinete de bolas
86	20 61 157		1	Kurbelgehäusedichtung 0,3 mm dick	crankcase gasket	joint de carter moteur	junta de carter
87	21 00 419		1	Kurbelgehäuse, Zünderseite	crankcase, ignition side	carter moteur côté VM	caja del cigüal
90	44 00 224 a	Ducati	1	Magnetrad 12,8	flywheel	volant magnétique	volante

Bild-Nr. Pos.-No. Pos.-No. Pos.-No.	Bestell-Nr. Order-No. No. de Cde. Ref.-Nr.	Modell Type Modèle Modelo	Menge Quantity Nombres Cantidad	Motor/ Gebläse	Engine/ Blower Housing	Moteur/ Carter de Turbine	Motor/ Caja del Ventilador
90	44 00 219	Prüfref		Magnetrad 12,8	flywheel	volant magnétique	volante
91	00 20 104 a	423 S	1	Sechskantmutter M10x1 DIN 936	nut	écrou	tuerca
92	00 18 399		6	Zylinderschraube M5x35	screw	vis	tornillo cilindrico
93	00 34 135		1	Schnorrnsicherung 10	circlip	arrêtage	seguro
100	27 00 318	423	1	Kraftstoffbehälter, kompl.	fuel tank, compl.	réservoir essence, compl.	depósito de gasolina, compl.
100	27 00 306	423 S	1	Kraftstoffbehälter, kompl.	fuel tank, compl.	réservoir essence, compl.	depósito de gasolina, compl.
101	27 00 178		1	Tankverschluß 32	tank cap	couvercle	tapa del deposito
101	27 00 180 +		1	Tankverschluß 32	tank cap	couvercle	tapa del deposito
102	00 61 107		1	Tankverschlußdichtung 19x27x1,5	gasket for tank cap	joint	junta
103	00 72 140		3	Scheibe 5,2x12x0,5 DIN 2093 A	spring washer	ressort	muelle de disco
104	00 18 257		3	Schraube 5x25	screw	vis	tornillo
107	00 62 267		1	O-Ring 12x2	o-ring	joint torique	anillo
108	00 62 116		1	O-Ring 9x2	o-ring	joint torique	anillo
110	27 00 340		1	Benzinhahn, kompl.	fuel tap, compl.	robinet d'essence, compl.	grifo gasolina, compl.
111	00 64 139		0,120	Schlauch 5x1,5	hose	tuyau	tubo
120	44 00 232	423	1	Gebläsegehäuse I	blower housing I	carter de turbine I	caja del ventilador I
120	44 00 266	423 S	1	Gebläsegehäuse I	blower housing I	carter de turbine I	caja del ventilador I
121	00 18 257		13	Schraube 5x25	screw	vis	tornillo
125	44 00 241		1	Laufgrad	fan wheel	turbine	turbina
126	00 34 135		1	Schnorrnsicherung 10	circlip	arrêtage	seguro
127	00 20 104 a		1	Sechskantmutter M10x1 DIN 936	nut	écrou	tuerca
130	44 00 236		1	Gebläsegehäuse II	blower housing II	carter de turbine II	caja del ventilador II
135	00 80 487		1	Kombischlüssel 21	combi wrench	clef à bougie	llave
136	20 73 266		1	Einfülltrichter	funnel	entonnoir	embudo de llenado
140	05 10 852	423	1	Reparatursatz-Vergaser Bing 1/15/106 bis 1990	repair-kit-carburetor	kit de réparation-carburateur	juego de reparacion-carburador
140	05 10 886	423	1	Reparatursatz-Vergaser Bing 1/15/110 bis 01/1991	repair-kit-carburetor	kit de réparation-carburateur	juego de reparacion-carburador
140	05 10 900	423	1	Reparatursatz-Vergaser Bing 1/15/110 ab 01/1991	repair-kit-carburetor	kit de réparation-carburateur	juego de reparacion-carburador
140	05 10 883	423 S	1	Reparatursatz-Vergaser Bing 1/15/110A	repair-kit-carburetor	kit de réparation-carburateur	juego de reparacion-carburador



Bild-Nr. Pos.-No. Pos.-No.	Bestell-Nr. Order-No. No. de Cde. Ref.-Nr.	Modell Type Modèle Modelo	Menge Quantity Nombres Cantidad	Behältergestell	Tank Frame	Chassis Réservoir	Deposito
1	40 74 271		1	Abflußstopfen 10/32x22/49	drainage plug	drainage plug	drainage plug
2	00 62 280		1	O-Ring 30x3	ring	ring	ring
3	40 63 143		1	Kugelbalg	siphon	siphon	siphon
4	00 73 350		1	Drahtschelle 51x2,5	clamp	clamp	clamp
5	40 74 265		1	Schraubkörper 64x3	threaded collar	threaded collar	threaded collar
6	40 74 265		1	Schraubkörper 64x3	threaded collar	threaded collar	threaded collar
10	42 00 203	423	1	Behälter/Gestell	tank frame, compl.	tank frame, compl.	tank frame, compl.
10	42 00 207	423 S	1	Behälter/Gestell	tank frame, compl.	tank frame, compl.	tank frame, compl.
13	00 62 280		1	O-Ring 30x3	ring	ring	ring
14	40 74 282		1	Stopfen 11x53	plug	plug	plug
15	00 64 138		0,350	Schlauch 8x2xmt.	hose	hose	hose
20	42 00 153		1	Einfullkorb, kompl.	liquid strainer, compl.	liquid strainer, compl.	liquid strainer, compl.
21	40 74 273		1	Schutzkappe 21x27	cap	cap	cap
22	40 61 342		1	Dichtring 99,5x111x4,2	gasket	gasket	gasket
23	40 73 170		1	Behälterdeckel	tank lid	tank lid	tank lid
25	00 28 121		4	Sechskantmutter M6	nut	nut	nut
26	00 30 125		4	Scheibe 6,4 DIN 9021	washer	washer	washer
27	00 12 172		4	Sechskantschraube M6x16 DIN 933	screw	screw	screw
28	00 18 311		4	Linsenschraube M6x14	screw	screw	screw
29	00 73 363		4	Dämpfungsfeder 3x22x24,5	av spring	av spring	av spring
32	40 74 962		5	Steckniet 5,7x18	rivet	rivet	rivet
32	00 44 144 +		5	Steckniet 5,7x18	cushion rivet	cushion rivet	cushion rivet
34	00 98 133		1	Rückenkissen	back cushion	back cushion	back cushion
36	43 00 33525		2	Tragegurt	carrying strap	carrying strap	carrying strap
37	40 74 83325		2	Befestigungshaken	plastic hook	plastic hook	plastic hook
38	43 00 329		2	Tragegurt	carrying strap	carrying strap	carrying strap
38	43 00 334 +		2	Tragegurt + Haken	strap + hook	strap + hook	strap + hook
40	40 74 412		2	Gurthalter	strap holder	strap holder	strap holder



Bild-Nr. Pos.-No. Pos.-No.	Bestell-Nr. Order-No. No. de Cde. Ref.-Nr.	Modell Type Modèle Modelo	Menge Quantity Nombres Cantidad	<b>Starter</b> mit Elektronik-Zündung	<b>Starter</b> with electronic ignition	<b>Lanceur</b> avec allumage électronique	<b>Arranque</b> con encendido electrónico
1	00 18 257		6	Linsenschraube 5x25	screw	vis	tornillo
2	00 69 285		1	SKS "SOLO Port"	decal "SOLO Port"	autocollant "SOLO Port"	etiqueta "SOLO Port"
5	21 00 481	423	1	Startergehäuse, kompl.	starter case, compl.	carter lanceur, compl.	caja de arranque, compl.
5	21 00 482	423 S	1	Startergehäuse, kompl.	starter case, compl.	carter lanceur, compl.	caja de arranque, compl.
6	00 63 178		1	Starterseil 4,3x1000	starter rope	câble de lanceur	cuerda de arranque
7	20 74 206		1	Startergriff	starter grip	poignée de lanceur	empunadura del starter
7	20 74 403 +		1	Startergriff	starter grip	poignée lanceur	empunadura
10	26 00 265		1	Rückzugfeder, kompl.	recoil spring, compl.	ressort de rappel, compl.	muelle de retroceso
11	20 74 345		1	Seilrolle	rope pulley, compl.	poulie de lanceur	roldana
12	20 74 369		1	Starterklinke	pawl	cliquet lanceur	trinquete
13	20 74 406		1	Kulisse	template	coulisse	colisa
14	00 73 364		1	Federstecker 1,5	pin	goupille	clavija
15	26 00 262	423	1	Starter kompl. (enth. Pos. 2-14)	starter, compl. (incl. 2-14)	lanceur, compl. (incl. 2-14)	arranque, compl. (incl. 2-14)
15	26 00 263	423 S	1	Starter kompl. (enth. Pos. 2-14)	starter, compl. (incl. 2-14)	lanceur, compl. (incl. 2-14)	arranque, compl. (incl. 2-14)
20	21 00 450	Prüfref	1	Zündergehäuse 42,50	ignition casing	carter allumage	carter encendido
20	21 00 495 a	Ducati	1	Zündergehäuse	ignition casing	carter allumage	carter encendido
22	00 18 348		2	Zylinderschraube M6x25	screw	vis	tornillo
23	00 18 400		1	Zylinderschraube M6x35	screw	vis	tornillo
25	23 00 487	Prüfref	1	Zündmodul Prüfref	ignition coil	volant électronique	bobina
25	23 00 800 a	Ducati	1	Zündmodul Ducati	ignition coil	volant électronique	bobina
26	00 72 148	Prüfref	2	Spannscheibe 4 DIN 6796	washer	rondelle spéciale	disco de tension
26	00 72 144 a	Ducati	2	Spannscheibe 5 DIN 6796	washer	rondelle spéciale	disco de tension
27	00 34 196	Prüfref	1	Zahnscheibe 4,3 DIN 6797	washer	rondelle	arandela
27	00 34 133 a	Ducati	1	Zahnscheibe 5,1 DIN 6797	washer	rondelle	arandela
28	00 18 394	Prüfref	2	Zylinderschraube M4x35	fill. head screw	vis	tornillo cilíndrico
28	00 18 399 a	Ducati	2	Zylinderschraube M5x35	fill. head screw	vis	tornillo cilíndrico
29	00 84 544	Prüfref	1	Massekabel 140	ground cable	câble	cable de masa
29	00 84 743 a	Ducati	1	Massekabel 140	ground cable	câble	cable de masa
30	20 35 269	Prüfref	1	Hülse	spacer sleeve	entretoise	tubo distanciador
30	00 64 292 a	Ducati	0,020	Silikonschlauch 6x1xmt.	hose	tuyau	tubo
31	00 73 385		1	Kontaktfeder	contact spring	ressort de contact	resorte de contacto
32	00 84 600		1	Kerzenstecker	spark plug cap	capuchon de bougie	tapa bujía
33	20 35 269		1	Distanzhülse 8,2/11x6,2x7,8	spacer sleeve	entretoise	tubo distanciador

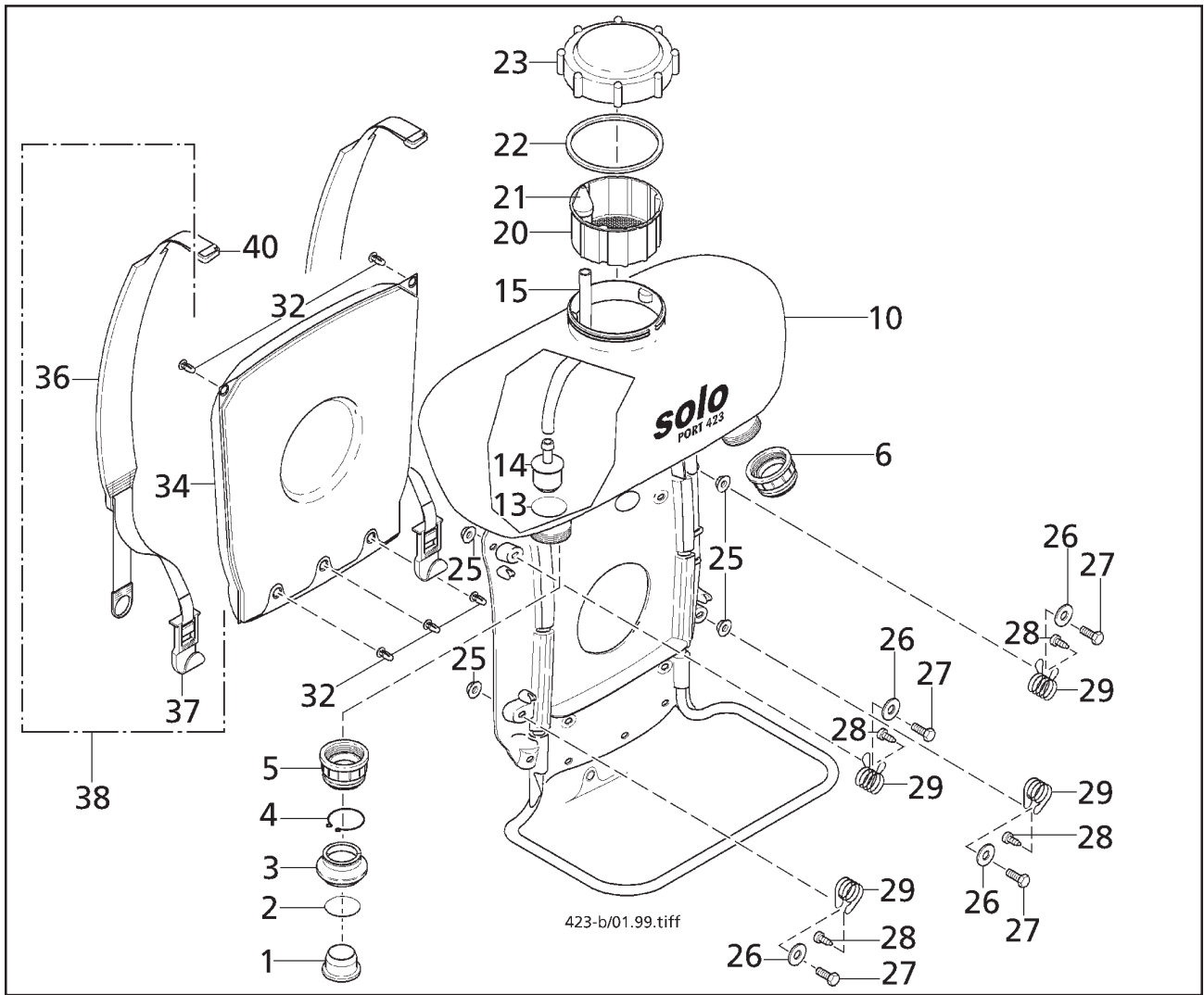

423-d/02.01.tiff

Bild-Nr. Pos.-No. Pos.-No. Pos.-No.	Bestell-Nr. Order-No. No. de Cde. Ref.-Nr.	Modell Type Modèle Modelo	Menge Quantity Nombres Cantidad	Sprührohr	Spray Tube	Tube atomiseur	Tube pulverizador
1	44 00 104 a		1	Gebläsekrümmer	blower elbow	coude souffleur	codo
3	00 18 257 a		1	Zylinderschraube 5x25	screw	vis	tornillo
4	00 66 130 a		1	Schelle Ø 83	clamp	collier	abrazadera
5	40 71 148 a		1	Faltenschlauch	pleated hose	tuyau souple	tubo flexible
6	00 66 399 a		1	Schelle Ø 68x10	clamp	collier	abrazadera
9	44 00 108 a		1	Sprührohr 63/65x590	spray tube	tube atomiseur	tubo pulverizador
11	00 10 328 a		1	Zylinderschraube M4x25 DIN 84	screw	vis	tornillo cilíndrico
12	00 20 106		1	Sechskantmutter M4 DIN 4032	nut	écrou	tuerca
14	40 73 141		1	Sprühdüse 50/62,5	spray nozzle	buse d'atomisation	tobera de pulverización
15	40 74 251		1	Düsenrohr 6/7x54	tube	tube	tubo
16	00 62 267		1	O-Ring 12x2	ring	joint bague	anillo
17	40 74 165		1	Dosierhülse 1,7/2,5/4/6,5	dosage sleeve	douille de dosage	tobera dosificadora
20	40 73 232		1	Weitstrahldüse	wide-angle nozzle	buse à diff. large	boquilla
21	40 74 721		1	Breitstrahlgitter	diffuser screen	grille à diff. large	pasador
22	40 73 142		1	Aufsatzdüse 54/86	cap nozzle	buse chapeau	boquilla
23	40 74 308		1	Umlenkigitter	deflector screen	grille déflectrice	pasador
24	40 74 306		1	Doppelgitter	double screen	grille double	pasador
25	49 00 264		1	Umlenkdüse 54/86 (enth.:	deflector nozzle, compl. (incl.:	buse déflectrice, compl. (incl.:	tobera, compl. (incl.:
(22)	40 73 142		1	Aufsatzdüse 54/86	cap nozzle	buse chapeau	boquilla
(23)	40 74 308		1	Umlenkigitter	deflector screen	grille déflectrice	pasador
28	28 00 559	423	1	Bowdenzug, Gas 1x1193, kompl.	bowden cable, gas, compl.	transmission de gaz, compl.	cable bowden para gas, compl.
28	28 00 558	423 S	1	Bowdenzug, Gas 1x993, kompl.	bowden cable, gas, compl.	transmission de gaz, compl.	cable bowden para gas, compl.
30	00 64 138		0,780,525	PVC-Schlauch 8x2xmt	hose	tuyau	tubo
31	40 74 658		2	Überwurfmutter R3/8"x12	screw cap	écrou de raccord	tuerca de racor
31	40 74 148 +		2	Überwurfmutter R3/8"x12,8	screw cap	écrou raccord	tuerca
32	40 74 355		2	Klemmhülse 8x11,4x22	connecting nipple	douille de serrage	acople
35	00 18 275		1	Linsenschraube 5x30	screw	vis	tornillo
36	40 73 624		1	Deckel	cover	couvercle	tapa
37	00 72 165		1	Tellerfeder 16,3x31,5x0,8	spring	rondelle	resorte
38	40 73 623		1	Gashebel	throttle lever	levier régulateur	palanca reguladora
40	00 11 274		2	Zylinderschraube 5x50	screw	vis	tornillo cilíndrico
40	00 18 276 +		2	Linsenschraube 5x35	screw	vis	tornillo
42	40 74 905		1	Kappe 25x15	cap	capuchon	tapa
45	00 62 248		1	O-Ring 6x2,5	ring	joint bague	anillo
46	00 62 263		1	O-Ring 12x2,5	ring	joint bague	anillo
47	40 74 481		1	Ventilkörper	valve body	corps de soupape	cuerpo valvula
48	00 70 271		1	Druckfeder 1,8x11,4x38	pressure spring	ressort de pression	resorte de presión
49	40 74 480		1	Deckel	cover	couvercle	tapa
50	40 74 479		1	Hebel	lever	levier	palanca
51	40 74 295		1	Bolzen 4,8x26,5	pin	boulon	perno
55	48 00 177		1	Handgriff, kompl. (enth. Pos. 35-37, 40-51)	handle, compl. (incl. 35-37, 40-51)	poignée, compl. (incl. 35-37, 40-51)	empunadura, compl. (incl. 35-37, 40-51)
55	48 00 190 +*		1	Handgriff, kompl. (enth. Pos. 35-51)	handle, compl. (incl. 35-51)	poignée, compl. (incl. 35-51)	empunadura, compl. (incl. 35-51)
*+:		423:	578.088→				
		423S:	35.781→				

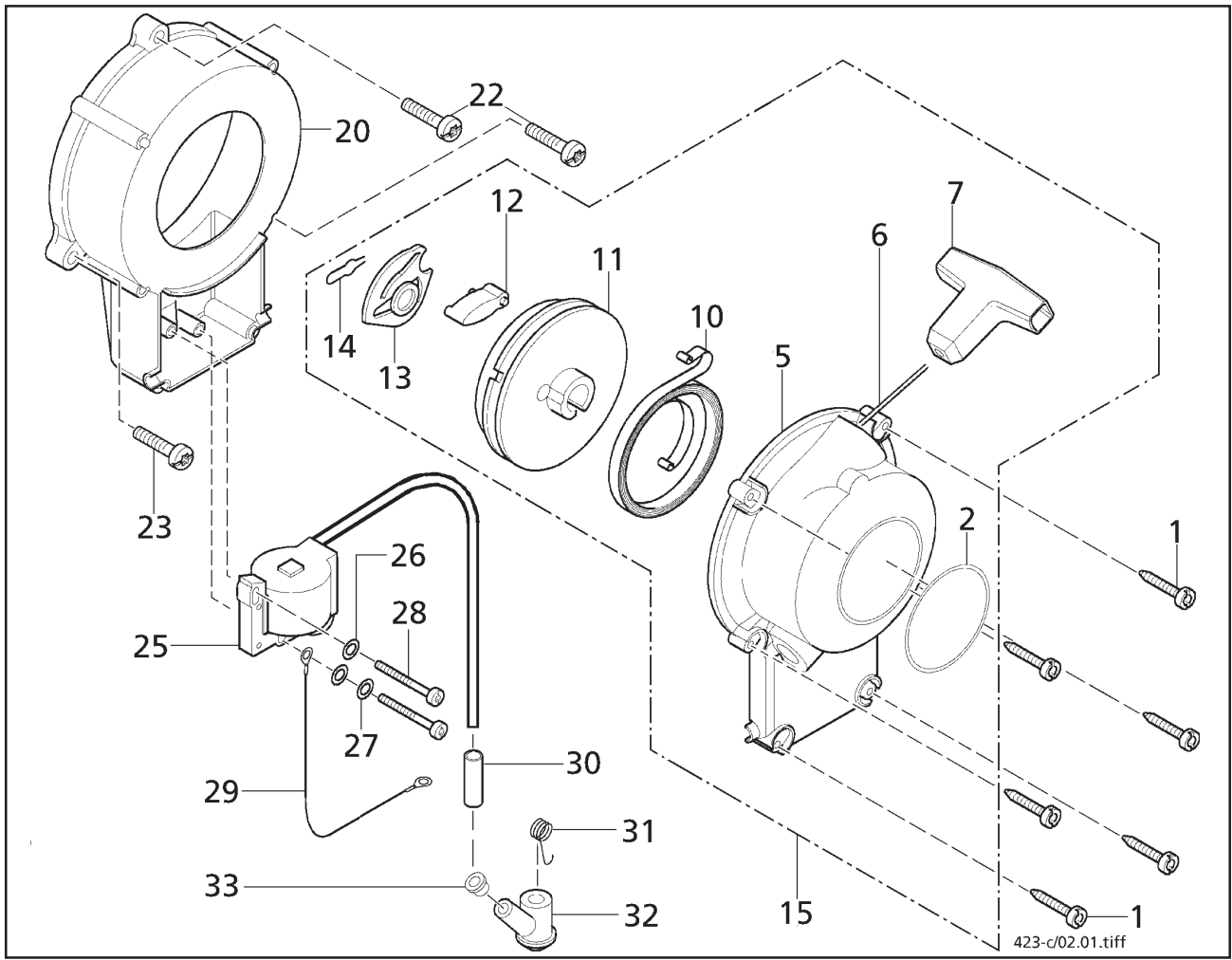
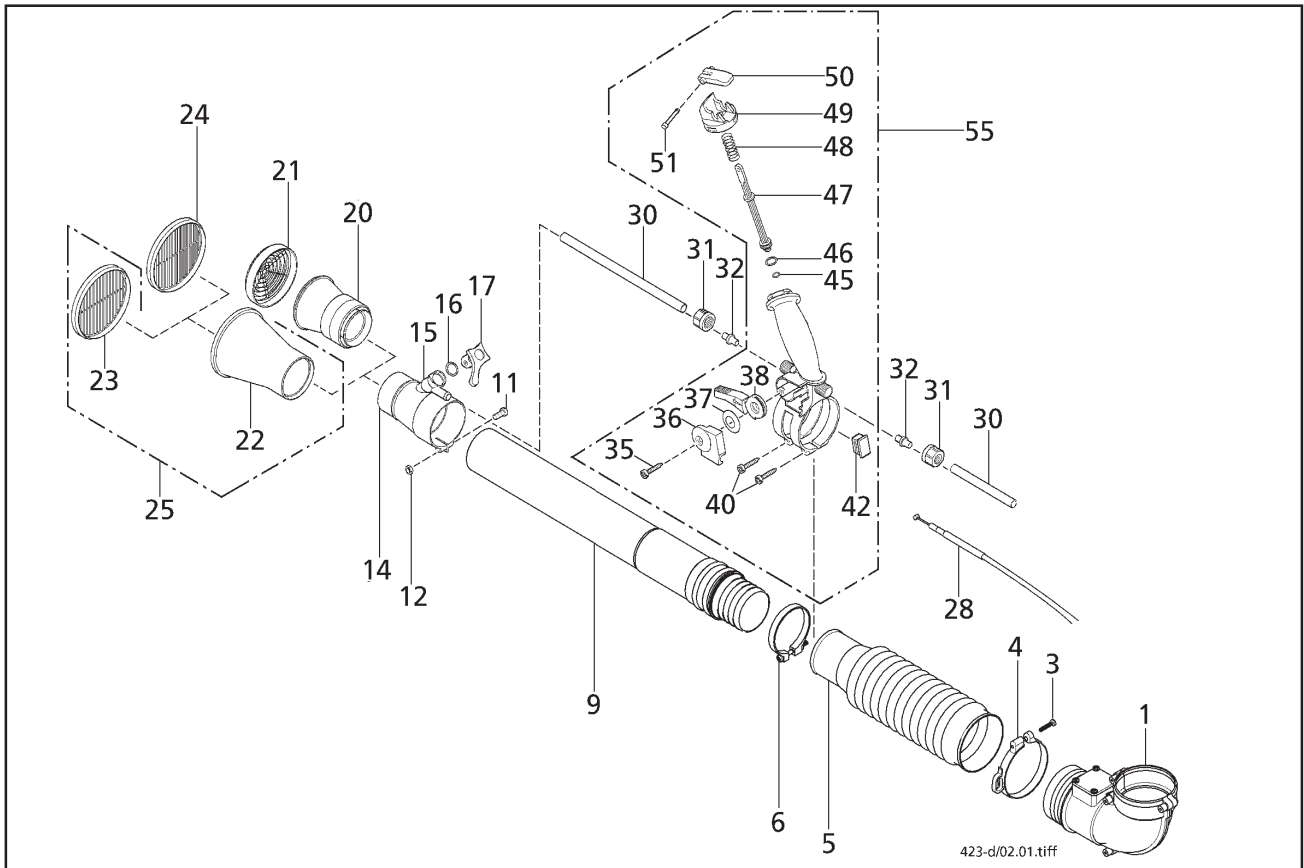



Bild-Nr. Pos.-No. Pos.-No. Pos.-No.	Bestell-Nr. Order-No. No. de Cde. Ref.-Nr.	Modell Type Modèle Modelo	Menge Quantity Nombres Cantidad	Zubehör *	Accessories *	Accessoires *	Accesorios *
1	42 00 103 a		1	Belüftungsverteiler	ventilation distributor	régulateur d'aération	distribuidor de ventilación
2	00 66 399 a		1	Schelle 68x10	clamp	collier	abrazadera
3	40 71 148 a		1	Faltenschlauch	pleated hose	tuyau souple	tubo flexible
4	00 66 130 a		1	Schelle	clamb	collier	abrazadera
5	00 18 257 a		1	Linsenschraube 5x25	screw	vis	tornillo
8	49 00 119 a		1	Blende m. Kupferdraht			
10	44 00 110 a		1	Gebälsekrümmer	blower elbow	coude de soufflerie	codo del ventilador
14	49 00 120 a		1	Dosiereinheit			
15	00 66 178		1	Schlauchklemme 25-40	hose clamp	collier de serrage du tuyau	collar de tubo
20	40 71 19927		1	Staubabfluß-Schlauch 31,5x376	drainage hose	tuyau d'évacuation	tubo de descarga
20	40 71 200+		1	Staubabfluß-Schlauch 31,5x331	drainage hose	tuyau d'évacuation	tubo de descarga
22	40 74 266		1	Abflußstutzen 32x45,5	drainage plug	manchon d'évacuation	apoyo para descarga
23	00 62 280		1	O-Ring 30x3	o-ring	joint torique	anillo
24	00 66 178		1	Schlauchklemme 25-40	hose clamp	collier de serrage du tuyau	collar de tubo
25	49 00 233		1	Stäubeteil, kompl. (enth. Pos.1-24)	dusting attachment, compl. (incl. 1-24)	dispositif de poudrage, compl. (incl. 1-24)	dispositivo de espolvoreo, compl. (incl. 1-24)
30	25 00 198		1	Einstecksieb	insert screen	tamis d'insertion	tamiz
31	40 74 274		1	Verteilerstopfen 32/10x52	distributor plug	bouchon	tapon
32	00 62 280		1	O-Ring 30x3	o-ring	joint torique	anillo
33	40 74 240		1	Dosierhülse 1/1,55/2,2/2,8	dosage sleeve	douille de dosage	casquillo
35	00 64 138		4	PVC-Schlauch 8x2xmt	hose	tuyau	tubo
36	40 74 148		1	Überwurfmutter R3/8"x12,8	screw cap	écrou raccord	tuerca
37	40 74 355		1	Klemmhülse	connecting nipple	douille serrage	casquillo
38	00 62 267		1	O-Ring 12x2	ring	joint bague	anillo
39	40 32 643		1	Zwischenstück M10x1x21 SW13	intermediate piece	pièces intermediaire	espaciador
40	40 74 239		1	Verschlusschraube M12x1,5	locking screw	vis de fermeture	tapa
-	00 66 317		1	Kabelband 140x9	cabale band	serre câble	cinta de cable
45	44 00 117		1	Flüssigkeitspumpe kompl. (enth.Pos.30-40)	liquid booster pump compl. (incl. 30-40)	pompe centrifuge compl. (incl. 30-40)	bomba de liquido compl. (incl. 30-40)
50	00 64 138		2	Schlauch 8x2	hose	tuyau	tubo
51	40 74 143		1	Verteilerstück 10x20	distributor piece	pièce distributrice	pieza de distribución
55	40 74 165		2	Dosierhülse 1,7/2,5/4/6	dosage sleeve	douille de dosage	casquillo dosificadora
56	00 62 267		2	O-Ring 12x2	o-ring	joint torique	anillo
60	00 10 208		2	Zylinder-Schraube M4x18 DIN 84 A	screw	vis	tornillo
61	00 20 106		2	Sechskantmutter M4 DIN 4032	nut	écrou	tuerca
65	40 73 155		1	Gabelstück	jet head	tête de gicleur	pieza en horquilla
67	00 10 146		1	Zylinderschraube M4x20 DIN 84 A	screw	vis	tornillo cilindrico
68	00 20 106		1	Sechskantmutter M4 DIN 934	nut	écrou	tuerca
-	40 73 238		2	Krümmerröhre 36/42	elbow nozzle	buse	codo
-	40 74 307		2	Dosierkörper	dosage barrel	douille de dosage	tobera
70	49 00 137		1	Doppelsprühdüse, kompl. (enth.Pos.50-68)	double nozzle, compl. (incl. 50-68)	douille double, compl. (incl. 50-68)	tobera doble, compl. (incl. 50-68)

\* Nicht im Lieferumfang enthalten.

\* Not included in standard supply and to be ordered separately.

\* Non-inclus dans la livraison. Objet d'une livraison complémentaire.

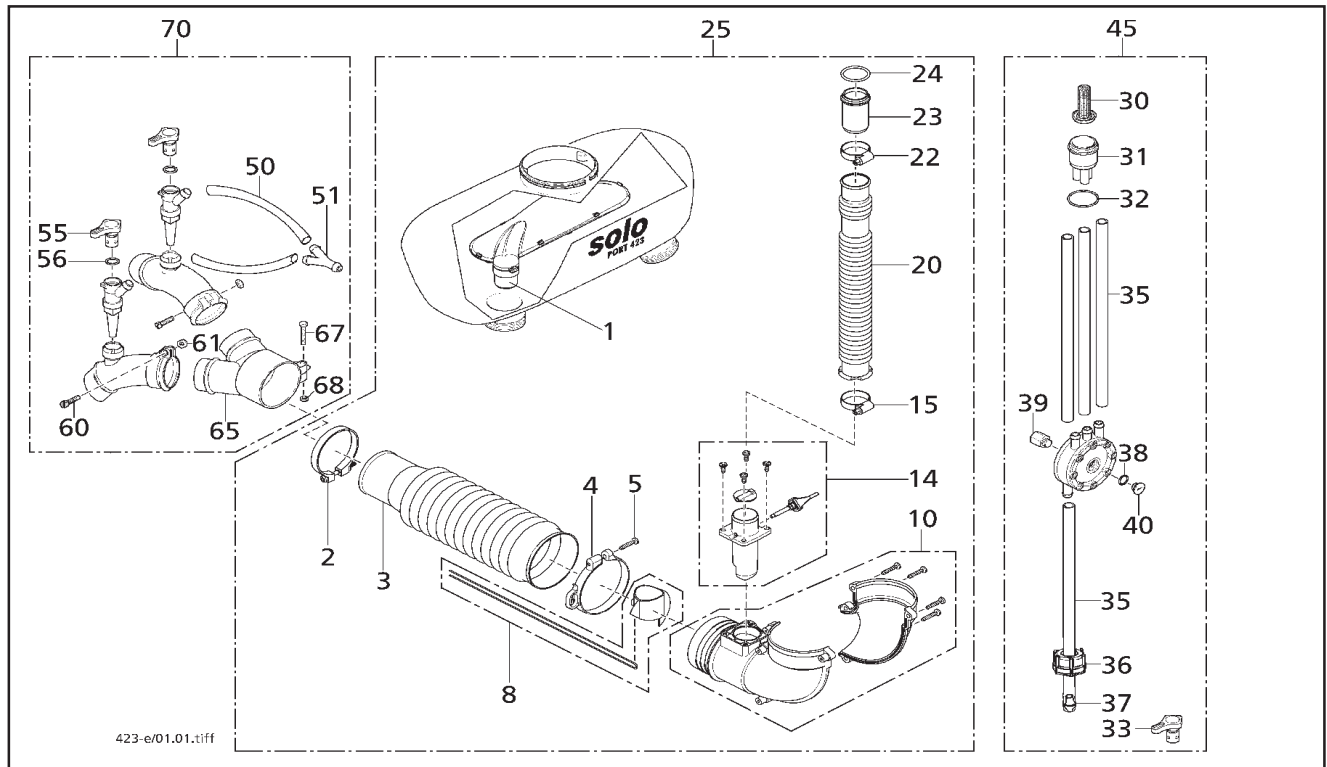
\* No forman parte de equipo standard. Hay que pedirlos separadamente.



Bild-Nr. Pos.-No. Pos.-No. Pos.-No.	Bestell-Nr. Order-No. No. de Cde. Ref.-Nr.	Modell Type Modèle Modelo	Menge Quantity Nombres Cantidad	Zubehör *	Accessories *	Accessoires *	Accesorios *
5	00 62 267		1	O-Ring 12x2	o-ring	joint torique	anillo
6	40 74 165		1	Dosierhülse 1,7/2,5/4/6,5	dosage sleeve	douille de dosage	casquillo
8	00 20 101		1	Sechskantmutter M5 DIN 934	nut	écrou	tuerca
9	00 10 182		1	Zylinderschraube M5x20 DIN 84 A	screw	vis	tornillo
12	49 00 412		1	Düse, compl. (enth.Pos.1-9)	nozzle, compl.(incl. 1-9)	buse, compl.(incl. 1-9)	tobera, compl.(incl. 1-9)
14	00 62 280		1	O-Ring 30x3	o-ring	joint torique	anillo
15	25 00 198		1	Einstecksieb	strainer	tamis	tamiz
16	40 74 271		1	Abflußstopfen 10/32x22/49	outlet plug	bouchon	tapon
17	00 64 412		1	Schlauch 8x2x780 mm	hose	tuyau	tubo
18	40 74 148		2	Überwurfmutter R3/8" x12,8	screw	écrou raccord	tornillo
19	40 74 355		2	Klemmhülse 8x11,4x22	connecting nipple	douille serrage	casquillo
20	00 64 412		1	Schlauch 8x2x400 mm	hose	tuyau	tubo
25	00 64 412		1	Schlauch 8x2x80 mm	hose	tuyau	tubo
26	40 32 668		1	Stutzen 8/9,8xM8x1	socket	manchon	boca
27	40 74 444		1	Dosierkörper	dosage piece	corps de dosage	cuerpo de graduación
28	40 21 149		1	Dosierschieber 0,5/0,8/1/1,2 mm Ø	slide valve	vanne de dosage	valvula dosificadora
30	00 10 370		1	Zylinderblechschraube 4,2x9,5 DIN 7971 C	screw	vis	tornillo
31	00 30 135		3	Scheibe 4,3 DIN 125 A	washer	rondelle	arandela
32	49 00 171		1	Federblatt	spring	ressort	resorte
33	40 74 445		1	Stutzen 8xM14x3	socket	manchon	munon
35	49 00 169		1	Dosiereinrichtung ULV-Zusatz, compl. (enth.Pos.15-33)	ULV dosage control kit, compl. (incl. 15-33)	disposit. dosage ULV,compl. (incl. 15-33)	dispositivo ULV,compl. (incl. 15-33)
-	00 64 412		1	Schlauch 8x2x350 mm	hose	tuyau	tubo
-	40 74 991		1	Dosierschieber 0,5/0,6/0,7/0,8 mm Ø	slide valve	vanne de dosage	valvula dosificadora

\* Nicht im Lieferumfang enthalten.

\* Not included in standard supply and to be ordered separately.

\* Non-inclus dans la livraison. Objet d'une livraison complémentaire.

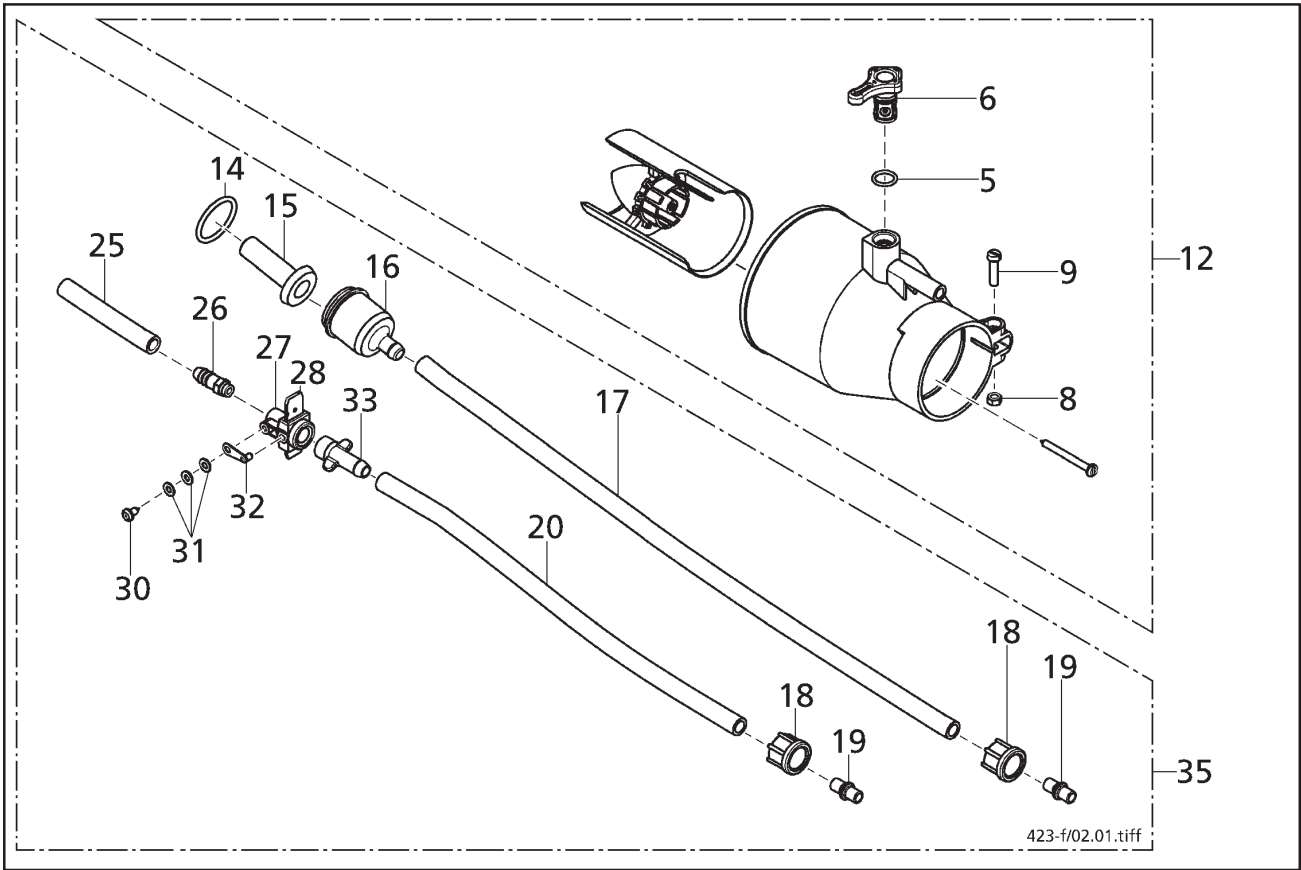
\* No forman parte de equipo standard. Hay que pedirlos separadamente.



Bild-Nr. Pos.-No. Pos.-No. Pos.-No.	Bestell-Nr. Order-No. No. de Cde. Ref.-Nr.	Modell Type Modèle Modelo	Menge Quantity Nombres Cantidad	Zubehör *	Accessories *	Accessoires *	Accesorios *
1	40 71 259		1	Umlenkkrümmen	elbow	coude	codo
2	40 73 458		2	Zwischenstück 62,5x102	intermediate piece	pièce intermédiaire	pieza intermedia
3	00 10 146		4	Zylinderschraube M4x20 DIN 84 A	screw	vis	tornillo
4	00 20 106		4	Sechskantmutter M4 DIN 934	nut	écrou	tuerca
5	40 65 184		1	Rohr 63x1,2x400	tube	tube	tubo
8	40 74 355		1	Klemmhülse 8x11,4x22	connecting nipple	douille serrage	casquillo
9	40 74 148		1	Überwurfmutter R3/8"x12,8	screw cap	écrou raccord	tuerca
10	00 64 138		0,60	Schlauch 8x2xmt.	hose	tuyau	tubo
15	49 00 355		1	Umlenkkrümmen kompl.(enth. Pos.1-10)	deflector elbow,compl.(1-10)	deflecteur, compl.(incl.Pos.1-10)	codo chorro angular,compl.(1-10)
20	40 65 137		1	Sprührohr 63x1,2x550	spray tube	tube atomiseur	tubo
21	00 64 138		0,60	Schlauch 8x2xmt.	hose	tuyau	tubo
22	00 65 267		1	Stutzen 8x5,6x56	socket	manchon	munon
23	40 73 458		1	Zwischenstück 62,5x102	intermediate piece	pièce intermédiaire	pieza intermedia
24	00 10 146		2	Zylinderschraube M4x20 DIN 84 A	screw	vis	tornillo
25	00 20 106		2	Sechskantmutter M4 DIN 934	nut	écrou	tuerca
30	49 00 333		1	Verlängerungsrohr 63x1,2x550,kompl. (enth. Pos.20-25)	ext. tube, compl. (incl. 20-25)	rallonge, compl. (incl. 20-25)	tubo ext., compl. (incl. 20-25)

\* Nicht im Lieferumfang enthalten.

\* Not included in standard supply and to be ordered separately.

\* Non-inclus dans la livraison. Object d'une livraison complémentaire.

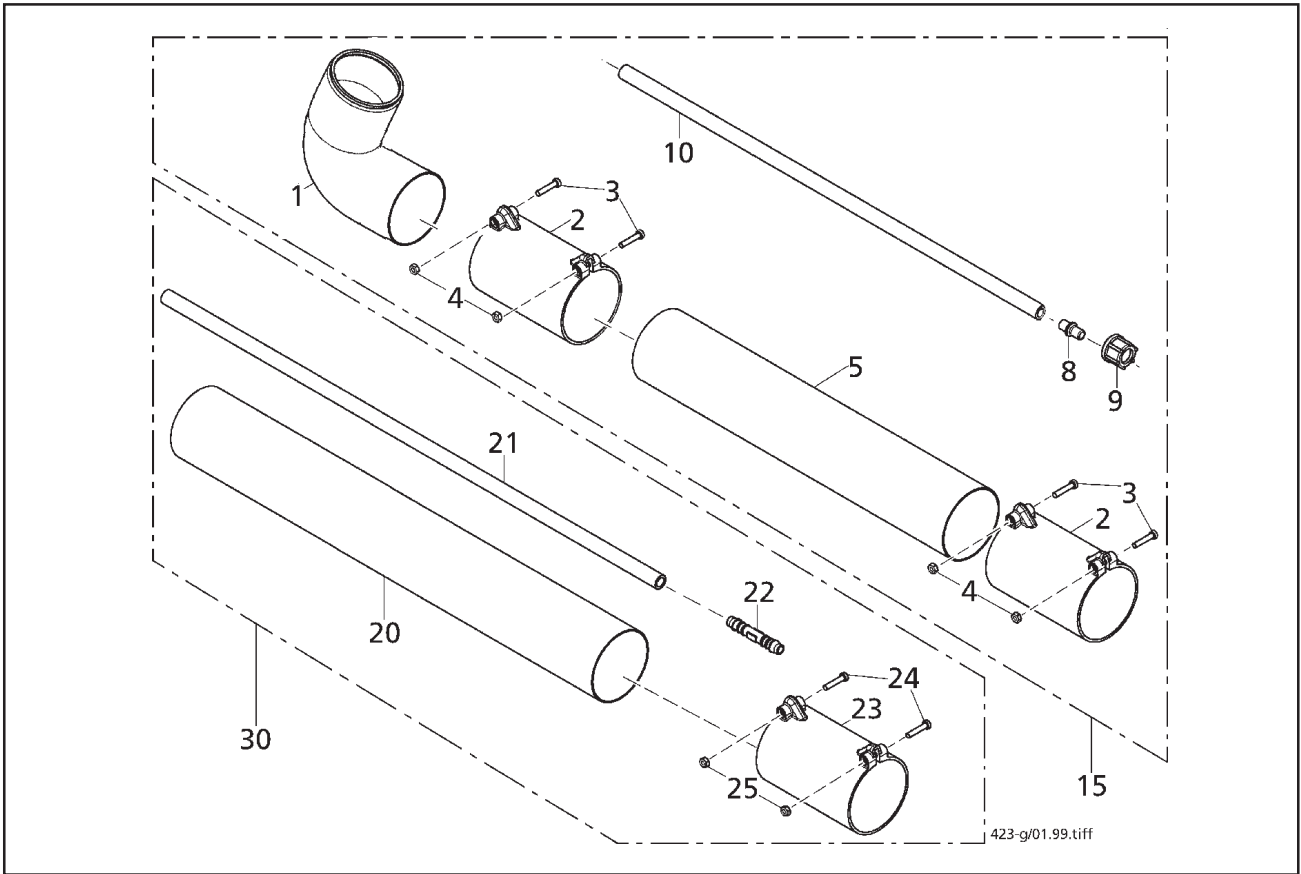
\* No forman parte de equipo standard. Hay que pedirlos separadamente.

Bestell-Nr. Order-No. No. de Cde. Ref.-Nr.	Menge Quantity Nombres Cantidad	Seite page page pagina	Bestell-Nr. Order-No. No. de Cde. Ref.-Nr.	Menge Quantity Nombres Cantidad	Seite page page pagina	Bestell-Nr. Order-No. No. de Cde. Ref.-Nr.	Menge Quantity Nombres Cantidad	Seite page page pagina	Bestell-Nr. Order-No. No. de Cde. Ref.-Nr.	Menge Quantity Nombres Cantidad	Seite page page pagina	Bestell-Nr. Order-No. No. de Cde. Ref.-Nr.	Menge Quantity Nombres Cantidad	Seite page page pagina
00 10 146	1	9	00 34 135	1	5	00 73 364	1	7	25 00 198	1	10	40 74 295	1	8
00 10 146	4	11	00 34 196	1	7	00 73 385	1	7	25 00 351	1	4	40 74 306	1	8
00 10 146	2	11	00 44 144 +	5	6	00 75 100	1	4	25 00 354	1	4	40 74 307	2	9
00 10 182	1	10	00 50 102	1	4	00 80 487	1	5	25 00 570	1	4	40 74 308	1	8
00 10 208	2	9	00 50 125	1	4	00 84 544	1	7	26 00 262	1	7	40 74 352	1	4
00 10 328 c	1	8	00 52 205	1	4	00 84 600	1	7	26 00 263	1	7	40 74 355	2	8
00 10 370	1	10	00 54 133	2	4	00 84 743 a	1	7	26 00 265	1	7	40 74 355	1	9
00 10 557	1	4	00 55 122	2	4	00 98 133	1	6	27 00 178	1	5	40 74 355	2	10
00 10 883	1	5	00 61 107	1	5	05 10 852	1	5	27 00 180 +	1	5	40 74 355	1	11
00 10 900	1	5	00 62 116	1	5	05 10 886	1	5	27 00 306	1	5	40 74 412		6
00 11 274	1	4	00 62 119	1	9	20 12 140	1	4	27 00 318	1	5	40 74 444	2	10
00 11 274	2	8	00 62 235	1	4	20 12 815 *a	1	4	27 00 340	1	5	40 74 445	1	10
00 12 172	4	6	00 62 248	1	8	20 23 366	1	4	28 00 558	1	8	40 74 479	1	8
00 12 368	3	4	00 62 263	1	8	20 23 367	1	4	28 00 559	1	4	40 74 480	1	8
00 15 209	4	4	00 62 267	1	5	20 31 168 25	1	4	28 00 559	1	8	40 74 481	1	8
00 18 257	2	4	00 62 267	1	8	20 35 269	1	7	40 21 149	1	10	40 74 658	1	8
00 18 257	3	5	00 62 267	1	9	20 35 269	1	7	40 32 643	1	9	40 74 721	2	8
00 18 257	13	5	00 62 267	2	9	20 43 338	1	4	40 32 668	1	10	40 74 833 25	1	6
00 18 257	6	7	00 62 267	1	10	20 43 411	1	4	40 61 342	1	6	40 74 905	2	8
00 18 257 a	1	9	00 62 280	1	6s	20 48 116	2	4	40 63 143	1	6	40 74 962	1	6
00 18 275	1	8	00 62 280	1	6	20 48 255	2	4	40 65 137	1	11	40 74 991	5	10
00 18 275 a	1	8	00 62 280	1	9	20 48 348	1	4	40 65 184	1	11	42 00 153	1	6
00 18 276 +	2	8	00 62 280	1	9	20 61 113	1	4	40 71 148 a	1	8	42 00 103 a	1	9
00 18 311	4	6	00 62 280	1	10	20 61 127	1	4	40 71 148 a	1	9	42 00 203	1	6
00 18 345	3	4	00 63 178	1	7	20 61 127 *a	1	4	40 71 199 27	1	9	42 00 207	1	6
00 18 345	1	4	00 64 138	1	6	20 61 140	1	4	40 71 200 +	1	9	43 00 329	2	6
00 18 345	1	4	00 64 138	2	8	20 61 157	1	4	40 71 259	1	11	43 00 334 +	2	6
00 18 348	4	4	00 64 138	4	9	20 61 336	1	4	40 73 141	1	8	43 00 335 25	2	6
00 18 348	2	7	00 64 138	2	9	20 73 266	1	5	40 73 142	1	8	44 00 104 a	1	8
00 18 394	2	7	00 64 138	1	11	20 73 455	1	4	40 73 155	1	9	44 00 108	1	8
00 18 399	6	5	00 64 138	1	11	20 73 500	1	4	40 73 170	1	6	44 00 110 a	1	9
00 18 399 a	2	7	00 64 139	1	5	20 74 196 *a	1	4	40 73 232	1	8	44 00 117	1	9
00 18 400	1	7	00 64 292 a	1	7	20 74 206	1	7	40 73 238	2	9	44 00 219	1	4
00 20 101	1	10	00 64 363	1	4	20 74 252	1	4	40 73 458	2	11	44 00 224 a	1	4
00 20 102	2	4	00 64 412	1	10	20 74 345	1	7	40 73 458	1	11	44 00 232	1	5
00 20 102	1	4	00 64 412	1	10	20 74 369	1	7	40 73 623	1	8	44 00 236	1	5
00 20 104 a	1	4	00 64 412	1	10	20 74 403 +	1	7	40 73 624	1	8	44 00 241	1	5
00 20 104 a	1	5	00 64 412	1	10	20 74 406	1	7	40 74 143	1	9	44 00 266	1	5
00 20 106	1	8	00 65 267	1	11	20 74 616	1	4	40 74 148	1	9	48 00 177	1	8
00 20 106	2	9	00 66 111 a	1	4	21 00 311	1	4	40 74 148	2	10	48 00 190 *+	1	8
00 20 106	1	9	00 66 130 a	1	8	21 00 419	1	4	40 74 148	1	11	49 00 119 a	1	9
00 20 106	4	11	00 66 130 a	1	9	21 00 450	1	7	40 74 148 +	2	8	49 00 120 a	1	9
00 20 106	2	11	00 66 178	1	9	21 00 481	1	7	40 74 165	1	8	49 00 137	1	9
00 20 142	1	4	00 66 178	1	9	21 00 482	1	7	40 74 165	2	9	49 00 169	1	10
00 20 160	1	4	00 66 317	1	9	21 00 495 a	1	7	40 74 165	1	10	49 00 171	1	10
00 21 100	1	4	00 66 399	1	4	22 00 111	1	4	40 74 239	1	9	49 00 233	1	9
00 28 121	4	6	00 66 399 a	1	8	22 00 241	1	4	40 74 240	1	9	49 00 264	1	8
00 30 125	4	6	00 66 399 a	1	9	22 00 628	1	4	40 74 251	1	8	49 00 333	1	11
00 30 135	3	10	00 69 285	1	7	22 00 935	1	4	40 74 265	1	6	49 00 355	1	11
00 31 375	2	4	00 70 271	1	8	22 00 946 a	1	4	40 74 265	1	6	49 00 412	1	10
00 34 107	2	4	00 72 140	3	5	23 00 106	1	4	40 74 266	1	9			
00 34 114	1	4	00 72 144 a	2	7	23 00 487	1	7	40 74 271	1	6			
00 34 114	1	4	00 72 148	2	7	23 00 558	1	4	40 74 271	1	10			
00 34 114	1	4	00 72 165	1	8	23 00 700	1	4	40 74 273	1	6			
00 34 133 a	1	7	00 73 350	1	6	23 00 800	1	7	40 74 274	1	9			
00 34 135	1	5	00 73 363	4	6	25 00 198	1	9	40 74 282	1	6			

#### Allgemeine Richtlinien für die Bestellung von Original SOLO Ersatzteilen:

Voraussetzung für eine reibungslose Erledigung sind folgende Angaben:

1. Ersatzteil-Bestellnummer
2. Gewünschte Anzahl
3. Typenbezeichnung des Geräts

Diese Ersatzteilliste ist für die Lieferung und Ausstattung von SOLO Erzeugnissen unverbindlich.

Im Interesse der technischen Weiterentwicklung bleiben Konstruktionsänderungen vorbehalten.

#### General Directions for Ordering Original SOLO Spare Parts:

Spare parts orders are to be placed with the SOLO Sales Branch or SOLO Distributor: For correct and diligent processing of your order, please give the following information:

1. Spare Part number
2. Quantity
3. Model and serial number
4. Shipping instructions

Delivery is made in accordance with our general sales and delivery conditions. This spare parts list is non-committal for us with regard to delivery and layout of SOLO products. In favour of technical improvements, design modifications are subject to change without notice.

#### Directives générales pour les commandes de pièces de rechange d'origine SOLO:

Il est indispensable de préciser dans toutes les commandes de pièces:

1. le numéro de référence de la pièce
2. - la quantité
3. - le type de la machine
4. - le mode d'expédition

Les livraisons sont effectuées dans le cadre de nos conditions générales de vente. Toutes modifications réservées.

#### Directivas Generales de pedido de la firma SOLO:

Por adelantado de un arreglo sin dificultades necesitamos siguientes indicaciones:

1. Número de repuesto
2. Numero de cantidad
3. Modelo y número de serial
4. Instrucción de Envío

Este lista de repuestos no es obligatoria para los envíos y/o forma de equipo de los productos SOLO.

En el interés del constante desarrollo debemos reservarnos el derecho de cambios.

#### SOLO Kleinmotoren GmbH

Postfach 60 01 52  
D-71050 Sindelfingen  
Germany

Telefon 07031/301-0  
Telefax 07031/301-130  
Export 07031/301-149

<http://www.solo-germany.com>  
e-mail: [info@solo-germany.com](mailto:info@solo-germany.com)

Zentral-Ersatzteilservice  
Telefon 07031/301-209  
Telefax 07031/301-206 09/01