

(D)	<i>Ersatzteilliste</i>	Motorsense	145L	Inhaltsverzeichnis	Seite
				Motor:	2 - 10
				Zylinder, Kurbelgehäuse	2
				Kolben, Kurbelwelle	3
				Haube, Luftführung	4
				Zündung	5
				Vergaser	6
				Luftfilter, Auspuff	7
				Benzintank	8
				Starter	9
				Kupplung	10
				Schaftrohr, Gasgriff, Loopgriff, Getriebe	11
				Getriebe, Schutz, Schneidwerkzeug	12
				Zubehör	12
				Richtlinien für die Bestellung	13
				Ersatzteile	14
(GB)	<i>Spare parts list</i>	Brushcutter	145L	Table of contents	Page
				Engine:	2 - 10
				Cylinder, crankcase	2
				Piston, Crankshaft	3
				Cooling-equipment	4
				Electric-equipment	5
				Carburetor	6
				Air-filter, Muffler	7
				Fuel-tank/fuel-valve	8
				Starter	9
				P.T.O-Equipment	10
				Shaft tube, throttle grip, handle "loop", gear	11
				Gear, protection, cutter	12
				Accessories	12
				Directions for ordering	13
				Spare parts	14
(F)	<i>Liste de pièces de rechange</i>	Debroussailleuses	145L	Table des matières	Page
				Moteur	2 - 10
				Tube, poignée acc, poignée "loop", engrenage	11
				Engrenage, protection, outil de coupe	12
				Accessories	12
				Directives pour les commandes	13
				Pièces de rechange	14
(E)	<i>Lista de piezas de recambio</i>	Desbrozadora	145L	Indice	Página
				Motor	2 - 10
				Tubo, acelerador, mango "loop", engranaje	11
				Engranaje, proteccion, herramienta de corte	12
				Accesorios	12
				Directivas de pedido	13
				Piezas de recambio	14



Bild-Nr. Pos.-No. No.Pos. Pos.-No.	Bestell-Nr. Order-No. No. de Cde Ref.-Nr.	Menge Quantity Nombres Cantidad	Motor: Zylinder, Kurbelgehäuse	Engine: Cylinder, crankcase
1	771200520	4	Bolzen 5x20 mm	BOLT-SOCKET,5X20
2	772140408	4	Schraube 4x8 mm	SCREW-PAN+-,4X8
3	772250535	4	Schraube 5x35 mm	SCREW-PAN-WSP-CROS,5X35
4	77110052159	1	Zylinder	CYLINDER-ENGINE
5	77110612173	1	Dichtung Zylinderfuß	GASKET,CYLINDER
6	77132712262	2	Abdeckblech	PLATE
7	77140802062	1	Kurbelgehäuse Kupplungsseite	CRANKCASE
8	77140802063	1	Kurbelgehäuse Starterseite	CRANKCASE
9	77340012089	1	Gehäuseboden	STAND
10	77920431302	2	Stift	PIN
11	77920452279	2	Kugellager	BEARING-BALL,6202C3
12	77920492259	2	Wellendichtring	SEAL-OIL,ISCD-15-25-7-F



Bild-Nr. Pos.-No. No.Pos. Pos.-No.	Bestell-Nr. Order-No. No. de Cde Ref.-Nr.	Menge Quantity Nombres Cantidad	Motor: Kolben, Kurbelwelle	Engine: Piston, crankshaft
1	77130012166	1	Kolben	PISTON-ENGINE
2	77130022067	1	Kolbenbolzen	PIN-PISTON
3	77130086067	1	Set Kolbenringe	RING-SET-PISTON
4	77130332063	1	Nadellager	BEARING-SMALL END
5	77491192231	1	Kurbelwelle	CRANKSHAFT-ASSY
6	77920262353	2	Distanzscheibe,	SPACER
7	77920332058	2	Sicherungsring	RING-SNAP

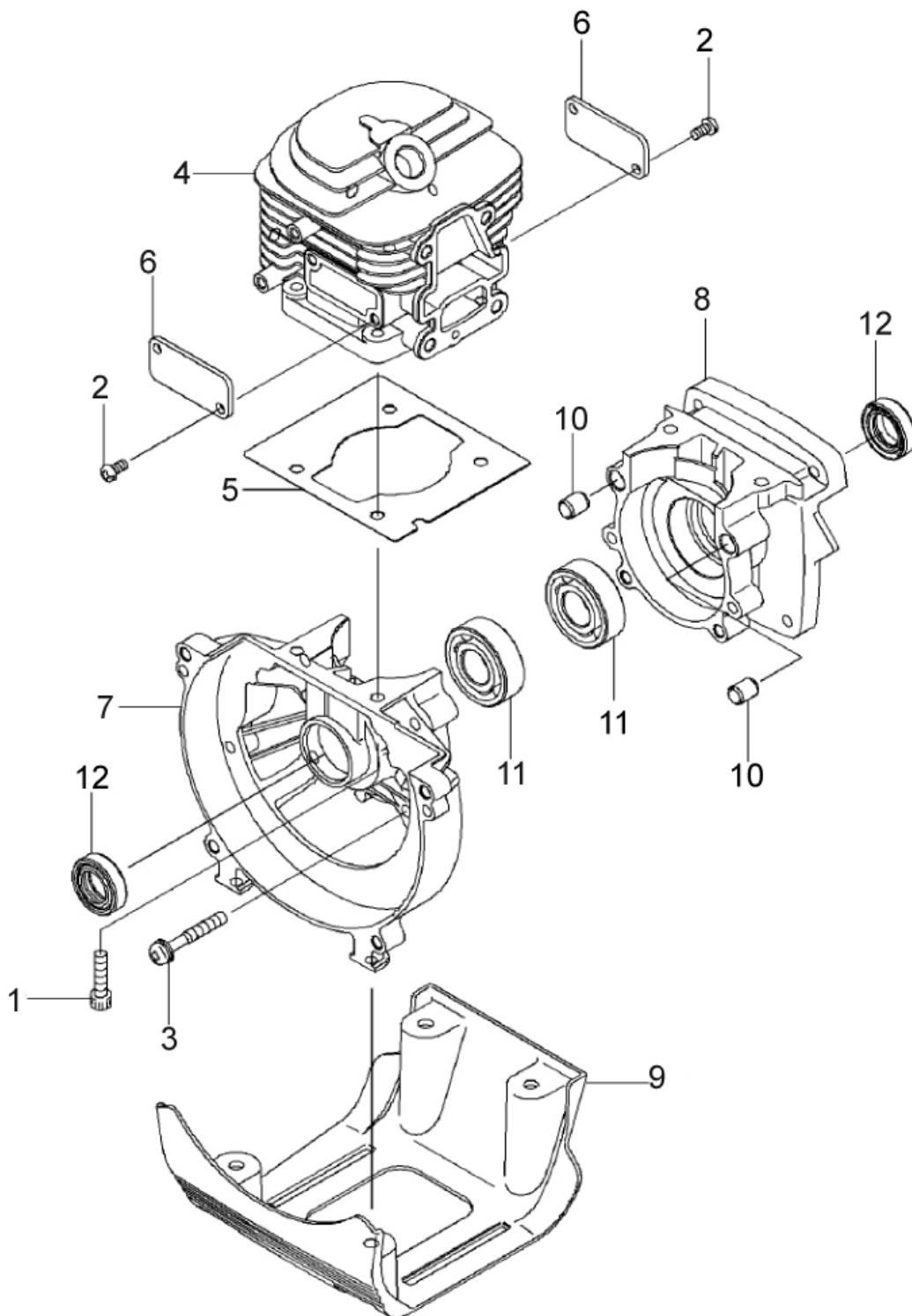

Bild-Nr. Pos.-No. No.Pos. Pos.-No.	Bestell-Nr. Order-No. No. de Cde Ref.-Nr.	Menge Quantity Nombres Cantidad	Motor: Haube, Luftführung	Engine: Cooling-equipment
1	772330516	4	Schraube 5x16 mm	SCREW-PAN-WP+;,5X16
2	77490892631	1	Haube	SHROUD-ENGINE
3	77590662797	1	Luftführung	HOUSING-FAN
4	77921722060	2	Schraube 4x10 mm	SCREW,4X10

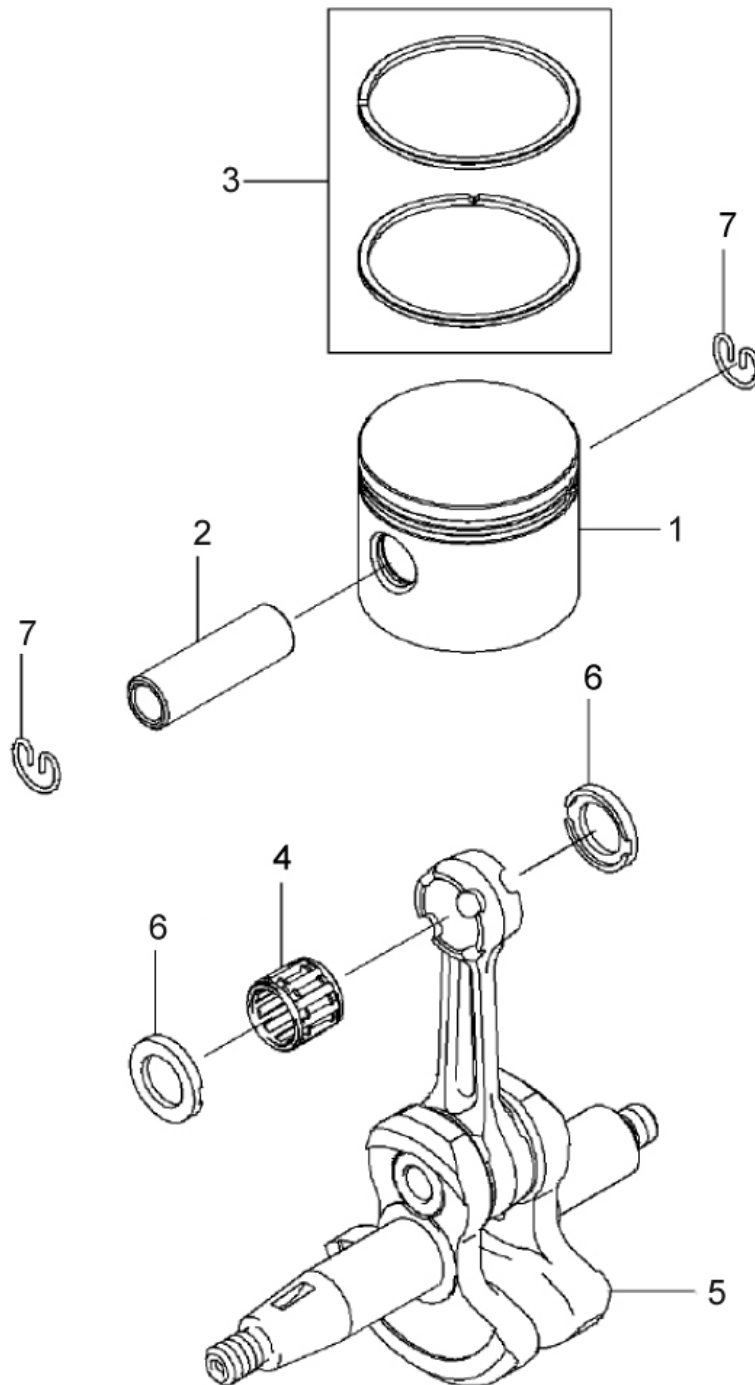

Bild-Nr. Pos.-No. No.Pos. Pos.-No.	Bestell-Nr. Order-No. No. de Cde Ref.-Nr.	Menge Quantity Nombres Cantidad	Motor: Zündung	Engine: Electric-equipment
1	775103100	1	Scheibenfeder	KEY-WOODRUFF
2	77160732220	2	Dämpfungselement	INSULATOR
3	77210502313	1	Polrad	FLYWHEEL
4	77211302072	1	Zündkerzenstecker	CAP-SPARK PLUG
5	77211692051	1	Kontaktfeder	TERMINAL
6	77211712250	1	Zündmodul	COIL-ASSY-IGNITION
7	77260112113	1	Masse-Kabel	WIRE-LEAD
8	77260112361	1	Zünd-Kabel	WIRE-LEAD, L=230
9	77920702107	1	Zündkerze	PLUG-SPARK, BPMR7A(NGK), SOLID
10	77921532135	2	Schraube 4x25 mm	BOLT, 4X25
11	77921702041	1	Halteblech	CLAMP
12	77921922165	1	Schlauch	TUBE, 6X6.6X80
13	77922102101	1	Mutter	NUT, M8

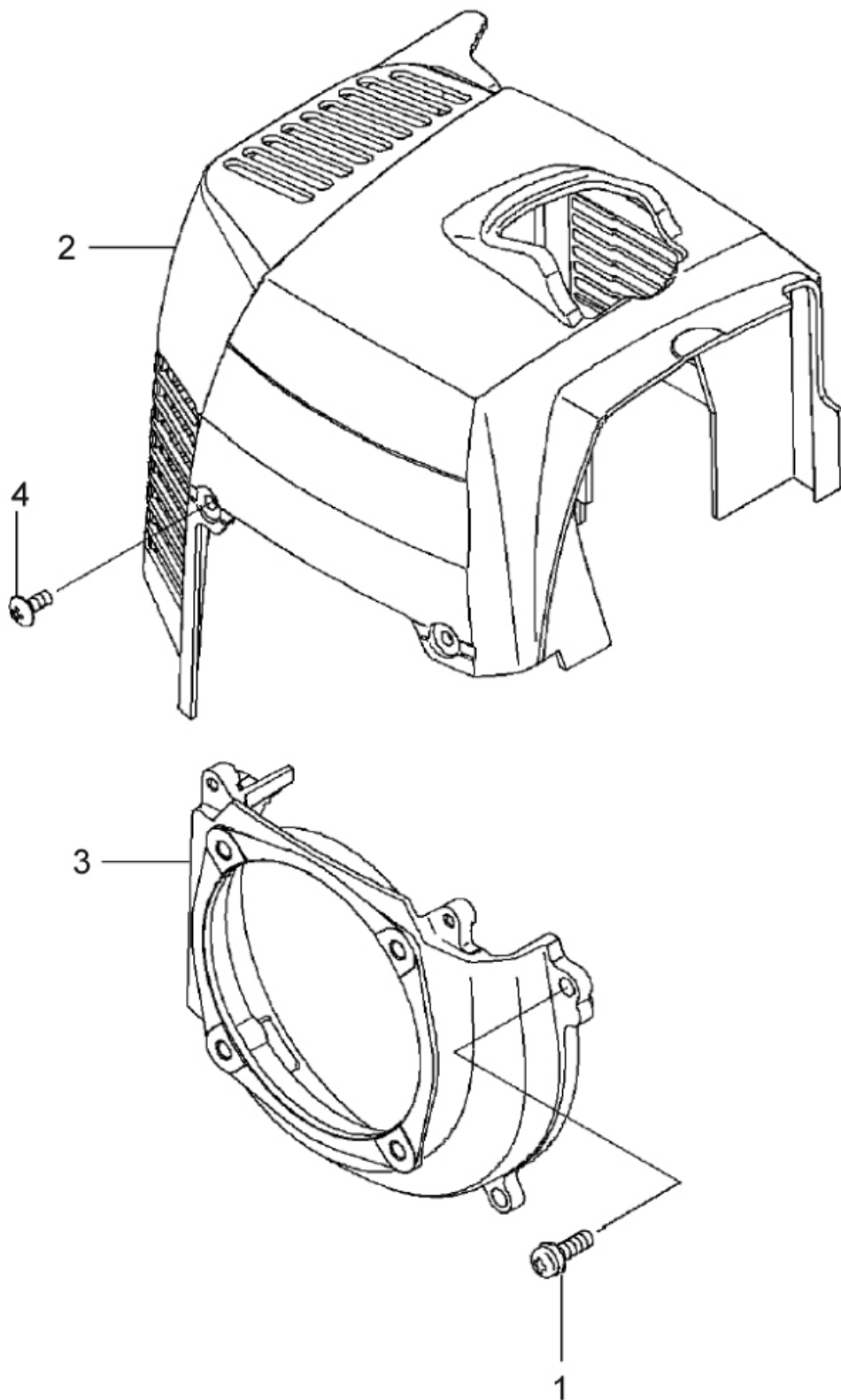

Bild-Nr. Pos.-No. No.Pos. Pos.-No.	Bestell-Nr. Order-No. No. de Cde Ref.-Nr.	Menge Quantity Nombres Cantidad	Motor: Vergaser	Engine: Carburetor
1	77110492006	1	Befestigung	BRACKET
2	77110602111	1	Dichtung	GASKET
3	77110612054	1	Dichtung	GASKET
4	77110612175	1	Dichtung Vergaser	GASKET,CARBURETOR-INSULATOR
5	77110612176	1	Dichtung	GASKET
6	77110612178	1	Dichtung Ansaugstutzen	GASKET,CYLINDER-INSULATOR
7	77120222059	1	Blattventil	VALVE-REED
8	77140432051	1	Filter	FILTER
9	77140902017	1	Gehäuse Primer	COVER,PRIMER PUMP
10	77150042050	1	Vergaser kpl.	CARBURETOR-ASSY
11	77160022056	1	Einstell-Bolzen	ADJUSTER-CABLE
12	77160302078	1	Schwimmerventil	VALVE-FLOAT
13	77160552051	1	Hebel	LEVER
14	77160732236	1	Flansch-Gehäuse	INSULATOR
15	77161602089	1	Boden	BODY
16	77161602103	1	Schwimmerkörper	BODY
17	77210832073	1	Einhängung Bowdenzug	ARM
18	77320852105	1	Anschlag	STOPPER
19	77430282067	1	Membran / Blende	DIAPHRAGM
20	77430282096	1	Membran / Blende	DIAPHRAGM
21	77490432067	1	Primer Pumpbalg	PUMP-PRIMING
22	77920092235	4	Schraube 5x25 mm	SCREW,5X25
23	77920092277	2	Schraube	SCREW
24	77920092336	1	Schraube	SCREW
25	77920092337	4	Schraube	SCREW
26	77920152145	1	Mutter	NUT
27	77920332078	1	Sicherungsring	RING-SNAP
28	77920432094	1	Stift	PIN
29	77920552147	1	O-Ring	RING-O
30	77920632483	1	Stopfen	JET-MAIN,#40
31	77921442308	1	Feder	SPRING
32	77921722091	1	Schraube 3x12 mm	SCREW,3X12
33	77922002074	1	Scheibe	WASHER

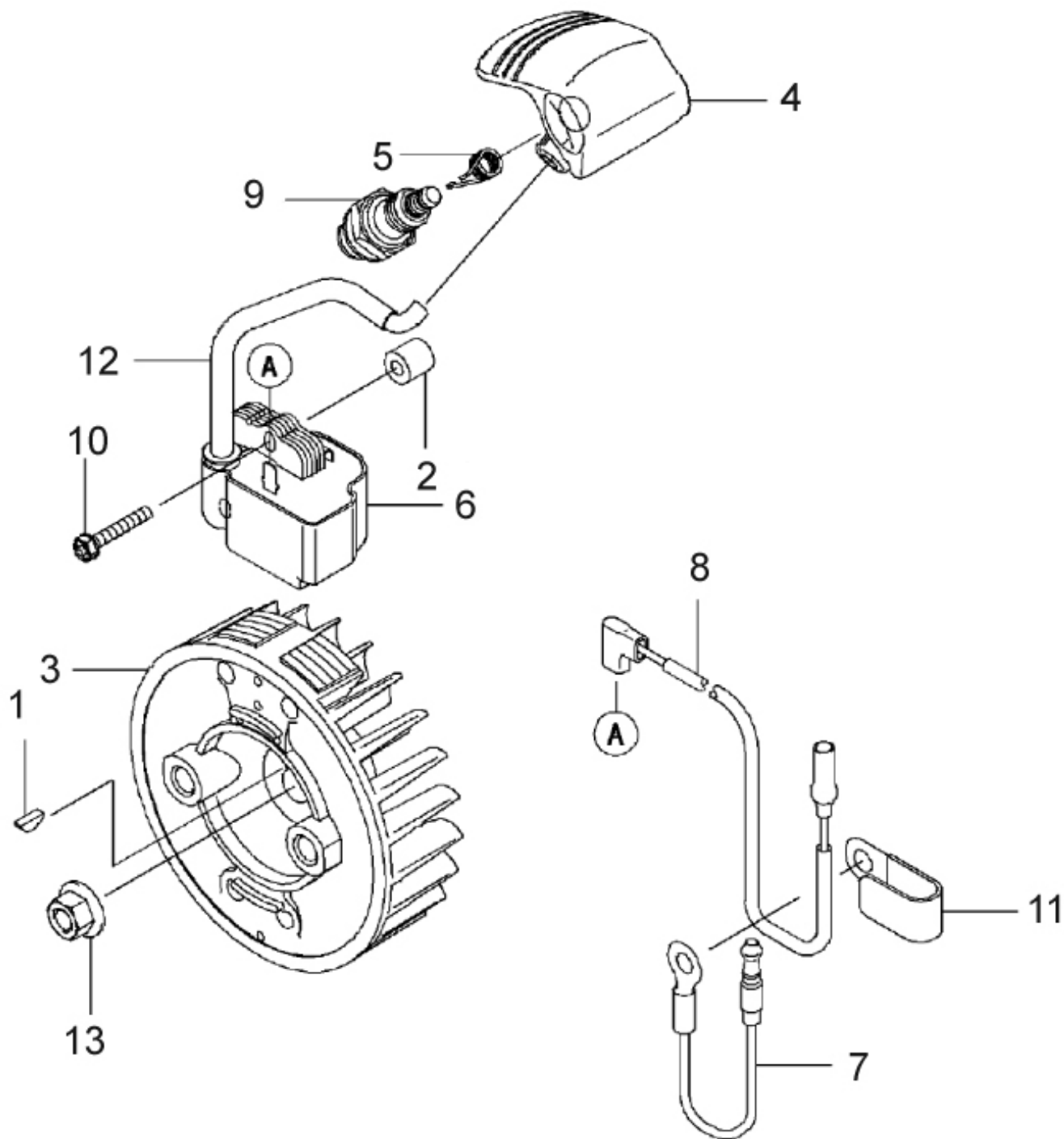

Bild-Nr. Pos.-No. No.Pos. Pos.-No.	Bestell-Nr. Order-No. No. de Cde Ref.-Nr.	Menge Quantity Nombres Cantidad	Motor: Luffilter, Auspuff	Engine: Air-filter, Muffler
1	771200516	2	Schraube 5x16 mm	BOLT-SOCKET,5X16
2	772340555	2	Schraube 5x55 mm	SCREW-PAN-WSP+,-,5X55
3	772420514	1	Schraube 5x14 mm	SCREW-PAN-WSP+,-,5X14
4	77110112362	1	Luffiltergehäuse Unterteil	CASE-AIR FILTER
5	77110132226	1	Schaumstofffilter	ELEMENT-AIR FILTER
6	77110612174	1	Dichtung Auspuff	GASKET,MUFFLER
7	77110652123	1	Luffilterdeckel	CAP
8	77180202091	1	Ablenklech	BAFFLE
9	77180772137	1	Funkenschutz	ARRESTER-SPARK
10	77490692430	1	Auspuff	MUFFLER-ASSY
11	77920092411	1	Schraube	SCREW
12	77921532128	1	Schraubverschluss	BOLT

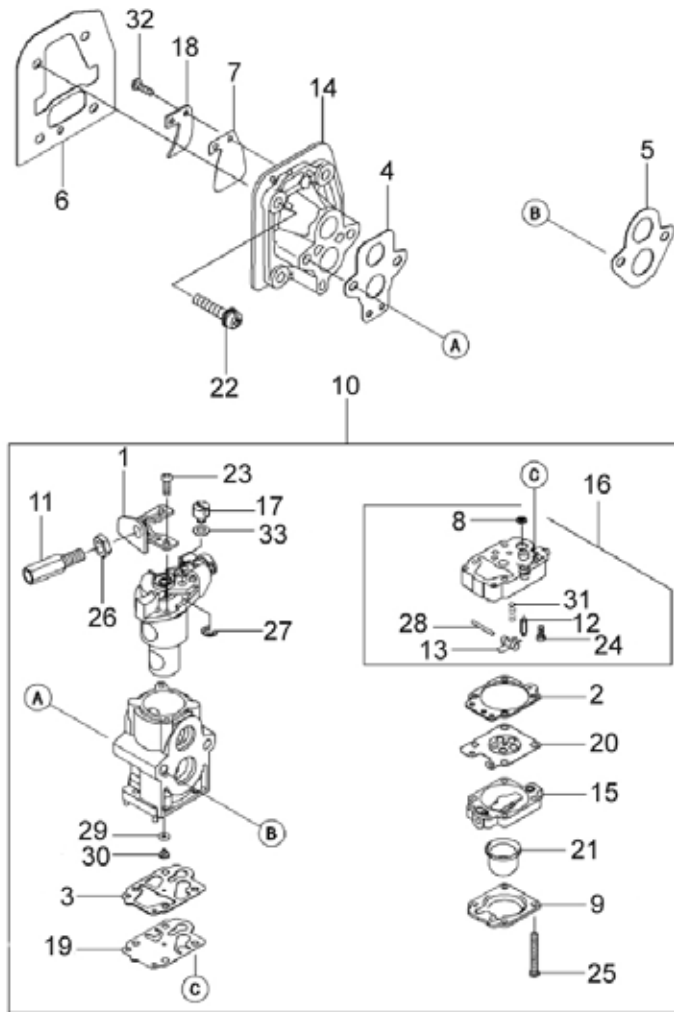

Bild-Nr. Pos.-No. No.Pos. Pos.-No.	Bestell-Nr. Order-No. No. de Cde Ref.-Nr.	Menge Quantity Nombres Cantidad	Motor: Benzintank	Engine: Fuel-tank/fuel-valve
1	77140692088	1	Entlüftung	BREATHER
2	77490192114	1	Benzinfilter	FILTER-FUEL
3	77510012324	1	Benzintank	TANK-COMP-FUEL
4	77510482083	1	Tankdeckel	CAP-ASSY-TANK
5	77920092383	3	Schraube 5x20 mm	SCREW,5X20
6	77920712142	1	Durchführung	GROMMET,FUEL TANK
7	77921712073	2	Schlauchöse	CLAMP
8	77921902157	1	Schlauch 3x5x200 mm	TUBE,3X5X200
9	77921922149	1	Schlauch 3x6x105 mm	TUBE,3X6X105
10	77999966089	1	Set Tankdeckel mit Entlüftung	CAP-TANK & BREATHER,ASSY

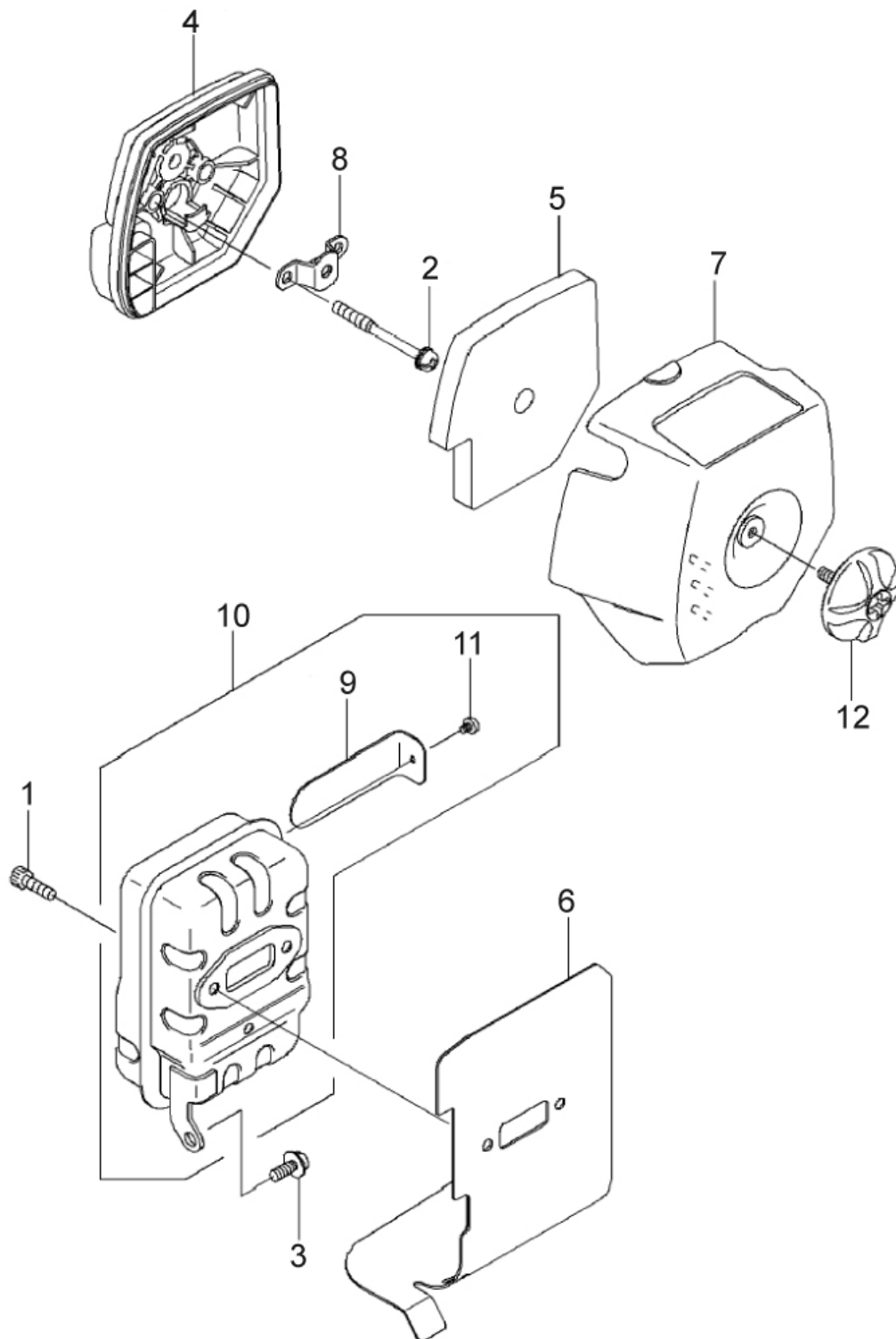

Bild-Nr. Pos.-No. No.Pos. Pos.-No.	Bestell-Nr. Order-No. No. de Cde Ref.-Nr.	Menge Quantity Nombres Cantidad	Motor: Starter	Engine: Starter
1	77131652107	2	Starterklinke	PAWL
2	77131692386	1	Platte Knotenbefestigung	PLATE,RECOIL STARTER
3	77460752129	1	Startergriff	GRIP,RECOIL STARTER
4	77490602065	1	Nockenscheibe	CAM,STARTER-RECOIL
5	77490802205	1	Klinkenträger	PULLEY-STARTING
6	77490882559	1	Set Starter	STARTER-RECOIL
7	77591012120	1	Seilrolle	REEL,STARTER-RECOIL
8	77591062064	1	Starterseil	ROPE,3.8X950
9	77920092249	4	Schraube 5x20 mm	SCREW,5X20
10	77920332010	2	Sicherungsring	RING-SNAP
11	77921452112	1	Feder	SPRING,SPIRAL
12	77921452148	2	Feder	SPRING
13	77921452150	1	Feder	SPRING
14	77921722100	1	Schraube	SCREW

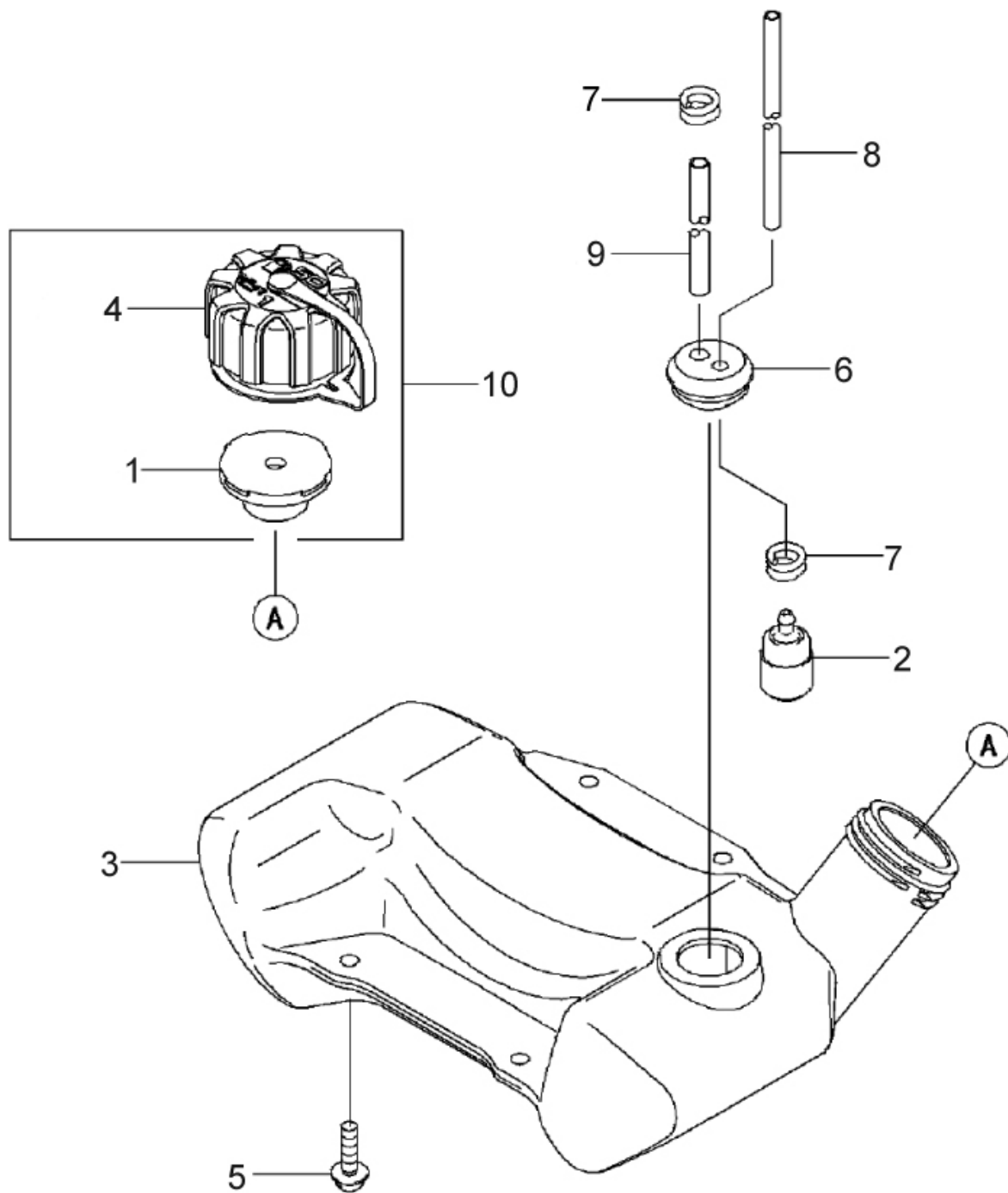

Bild-Nr. Pos.-No. No.Pos. Pos.-No.	Bestell-Nr. Order-No. No. de Cde Ref.-Nr.	Menge Quantity Nombres Cantidad	Motor: Kupplung	Engine: P.T.O-EQUIPMENT
1	77130812220	1	Kupplung komplett	CLUTCH-ASSY
2	77490492075	2	Kupplungsschuh	SHOE-CLUTCH
3	77920262125	2	Scheibe	WASHER
4	77920432210	2	Kupplungsbolzen	PIN,CLUTCH
5	77921442390	1	Kupplungsfeder	SPRING
6	77922002064	2	Tellerfeder	WASHER,SPRING,10.5X14.5X0.3

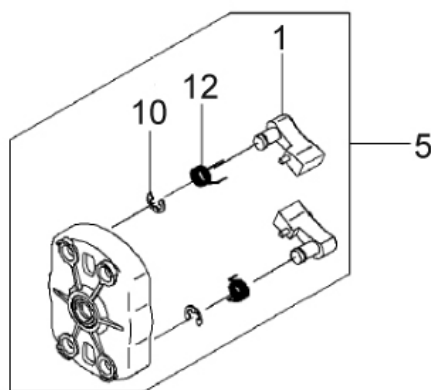
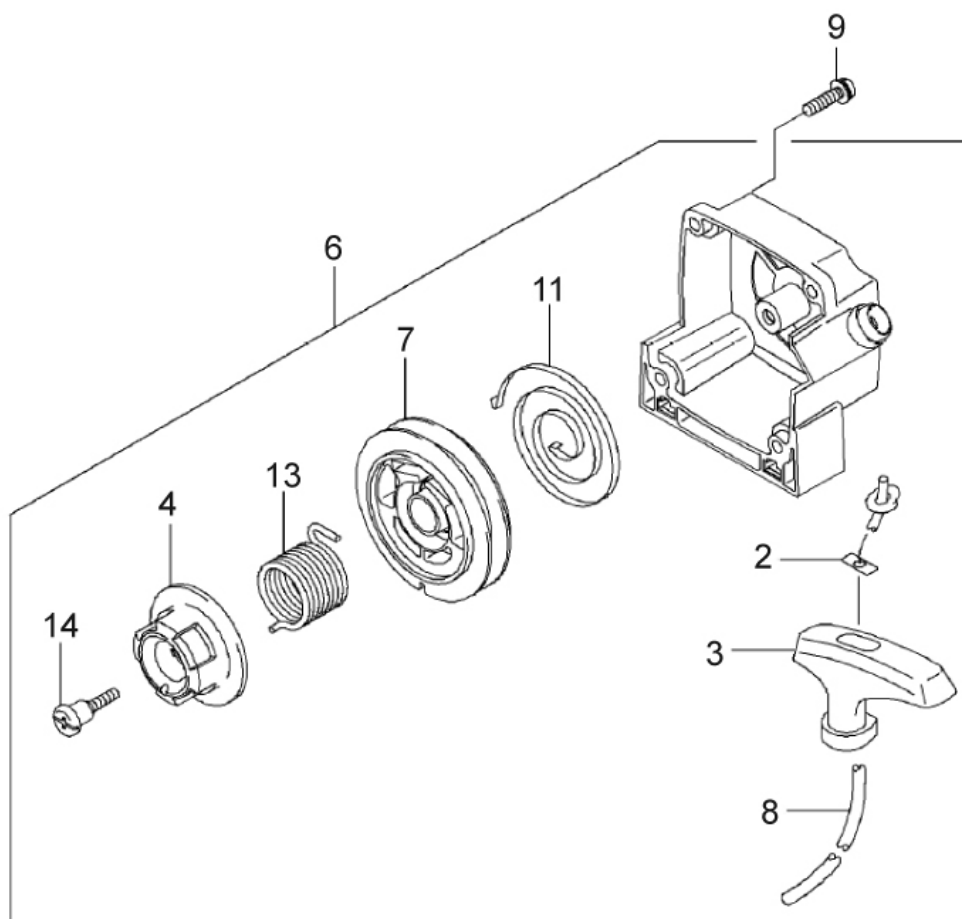

Bild-Nr. Pos.-No. No.Pos. Pos.-No.	Bestell-Nr. Order-No. No. de Cde Ref.-Nr.	Menge Quantity Nombres Cantidad	Schaftrohr, Gasgriff, Loopgriff, Getriebe	Shaft tube, throttle grip, handle "loop", gear	Tube, poignée acc, poignée "loop", engrenage	Tubo, acelerador, mango "loop", engranaje
1	21 00 881	1	Flanschgehäuse kpl.	Flange housing	Boîtier bride	Caja de brida
2	63 00 369	1	Schaftrohr enth.: (->2 - 4	Shaft tube incl. (->2 - 4	Tube y inclus (->2 - 4	Tubo incl. (->2 - 4
4	00 69 382	1	Aufkleber Warnhinweise <-)	Decal sign	Autocollant	Adhesivo
5	60 35 392	1	Welle 8 x 1553 mm	Drive shaft	Arbre	Arbol
6	30 00 236	1	Getriebe	Gear	Engrenage	Engranaje
7	00 18 453	4	Zylinderschraube M6 x 20 mm	F.H. screw	Vis	Tornillo
8	00 34 120	4	Sicherungsscheibe	Safety washer	Rondelle de sécurité	Arandela seguridad
9	00 33 426	1	Distanzrohr-10x2,3x10 mm	Spacer tube	Tube d'entretoise	Tubo distanciador
10	20 74 899 52	1	Klemme 2	Clamp	Collier	Abrazadera
11	00 18 434	1	Zylinderschraube M4x30 mm	F.H. screw	Vis	Tornillo
12	00 72 148	1	Sicherungsscheibe 4 mm	Safety washer	Rondelle de sécurité	Arandela seguridad
13	68 00 864	1	Loopgriff	Handle "loop"	Poignée "loop"	Mango "loop"
14	68 00 255	1	Griffhälfte links	Grip half	Poignée extérieure	Cascara
15	20 74 260	1	Halbgasschalter	Switch	Interrupteur	Interruptor
16	00 84 901	1	Kabel-Masse-Kurzschluss	Ground cable	Câble masse	Cable de masa
17	28 00 592	1	Bowdenzug-Gas	Throttle cable	Câble des gaz	Cable bowden
18	68 00 254	1	Griffhälfte rechts	Grip half	Poignée extérieure	Cascara
19	00 84 888	1	Kurzschlussschalter	Stop-switch	Switch arret	Interruptor
20	20 74 261	1	Gashebel	Throttle lever	Levier de gaz	Palanca de gas
21	00 73 437	1	Schenkelfeder-Gashebel	Spring	Ressort d'interrupteur	Muelle
22	20 74 262	1	Sicherungshebel	Safety lever	Levier de sécurité	Palanca
23	00 43 107	1	Drahtstift 10x10	Pin	Goujon	Perno
24	00 94 344 25	2	Schwingungsdämpfer D28	Av element	Amortisseur	Elemento av
25	00 18 226	3	PT Schraube 5x40 mm	Screw	Vis	Tornillo
26	00 18 274	2	PT Schraube 5x16 mm	Screw	Vis	Tornillo
28	60 43 989	2	Schelle 28	Clamp	Collier	Abrazadera
29	00 21 241	2	4KT Mutter M5	Nut	Ecrou	Tuerca
30	00 18 338	2	Zylinderschraube M5 x 25	F.H. screw	Vis	Tornillo
31	69 00 924	1	Tragegurt kpl. enth.: (->31 - 34	Carrying strap incl. (->31 - 34	Bretelle y inclus (->31 - 34	Cinturon portador incl. (->31 - 34
32	20 74 935	1	Gurtbefestigung mit Lasche	Harness hook	Support de bretelle	Soporte cinturón
33	20 74 936	1	Gurtbefestigung	Harness hook	Support de bretelle	Soporte cinturón
34	00 18 357	2	Linsenschraube 4x25 mm	Screw	Vis	Tornillo

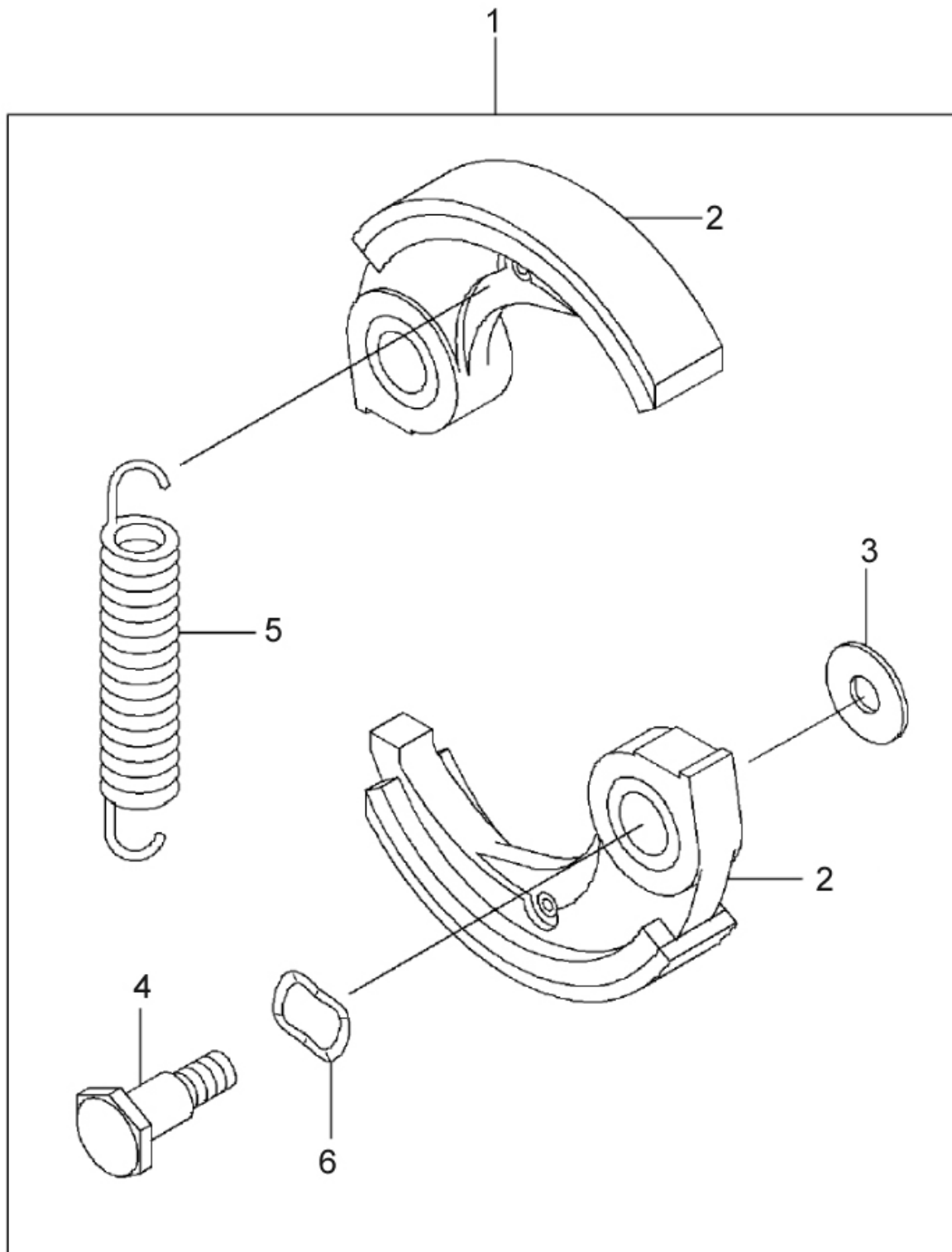

9133700_11

Bild-Nr. Pos.-No. No.Pos. Pos.-No.	Bestell-Nr. Order-No. No. de Cde Ref.-Nr.	Menge Quantity Nombres Cantidad	Getriebe, Schutz, Schneidwerkzeug	Gear, protection, cutter	Engrenage, protection, outil de coupe	Engranaje, proteccion, herramienta de corte
1	69 00 107	1	Schutz komplett enth.: (->1 - 11	Protection incl. (->1 - 11	Protection y inclus : (->1 - 11	Proteccion incl. (->1 - 11
2	20 43 510	1	Abstützung	Support	Support	Soporte
3	20 73 125	1	Schutz	Protection	Protection	Proteccion
4	69 00 106	1	Schutzleiste kpl. enth.: (->4 - 7	Protection rail cpl. incl. (->4 - 7	Listeade protection cpl. y inclus : (->4 - 7	Liston de proteccion cpl incl. (->4 - 7
5	00 28 157	2	Blechmutter	Nut	Ecrou	Tuerca
6	20 42 713	1	Fadenbegrenzungsmesser	Knife	Couteau	Cuchilla
7	00 18 335	2	Zylinderschraube M5x12 mm<-)	F.H. screw <-)	Vis <-)	Tornillo <-)
8	00 18 363	2	PT Schraube 5x20 mm	Screw	Vis	Tornillo
9	20 73 126	1	Deckel	Lid	Couvercle	Tapa
10	00 94 346	2	Zwischenlage 50x40x1 mm	Ply	Piece d'entretoise	Capa intermedia
11	00 18 276	2	PT-Schraube-5x35 mm <-)	Screw <-)	Vis <-)	Tornillo <-)
12	30 00 236	1	Getriebe	Gear	Engrenage	Engranaje
13	69 00 655 6	1	Fadenkopf enth.: (->13 - 15	Nylon head incl. (->13 - 15	Tête fils y inclus : (->13 - 15	Cabezal de hilo incl. (->13 - 15
14	69 00 942	15 m	Ersatzfaden Ø 2,4 mm	Replacement line	Recharge fils	Hilo de recambio
15	20 74 870	1	Wickelschutz <-)	Anti-clogging device <-)	Protecteur d'enroulement <-)	Proteccion de arrollamiento <-)
16	00 80 514 25	1	Montagestift 5 mm	Locking pin	Goupille de montage	Perno
17	30 31 500	1	Druckstück	Pressure part	Pièce de pression	Pieza de presion
18	30 31 501	1	Druckscheibe	Washer	Rondelle	Disco
19	30 43 427	1	Lauffeller	Nut protector	Disque de glissement	Plato de motriz
20	00 20 223	1	Sechskantmutter M10x1,25 mm	Nut	Écrou	Tuerca
21	00 80 509	1	Kombischlüssel SW19/T25	Combi wrench	Clef combi	Llave combi
			Zubehör	Accessories	Accesorios	Accesorios
22	69 00 948	1	Grasschneideblatt, 4 Zähne Ø 230 mm	Grass cutt. Blade 4-t	Lame herbe, 4-dents	Hoja de corte, 4 dientes
23	69 00 947	1	Dickichtmesser 3 Zähne Ø 250 mm	3-tooth brush blade shaft	Lame à broussailles 3 dents	3 cuchilas en forma de Z para matorral
24	60 73 534	1	Transportschutz bis Ø 250 mm	Transport protection	Protection transport	Proteccion transporte
23	69 00 943	1	Dickichtmesser 3 Zähne Ø 300 mm	3-tooth brush blade shaft	Lame à broussailles 3 dents	3 cuchilas en forma de Z para matorral
24	60 73 549	1	Transportschutz bis Ø 300 mm	Transport protection	Protection transport	Proteccion transporte

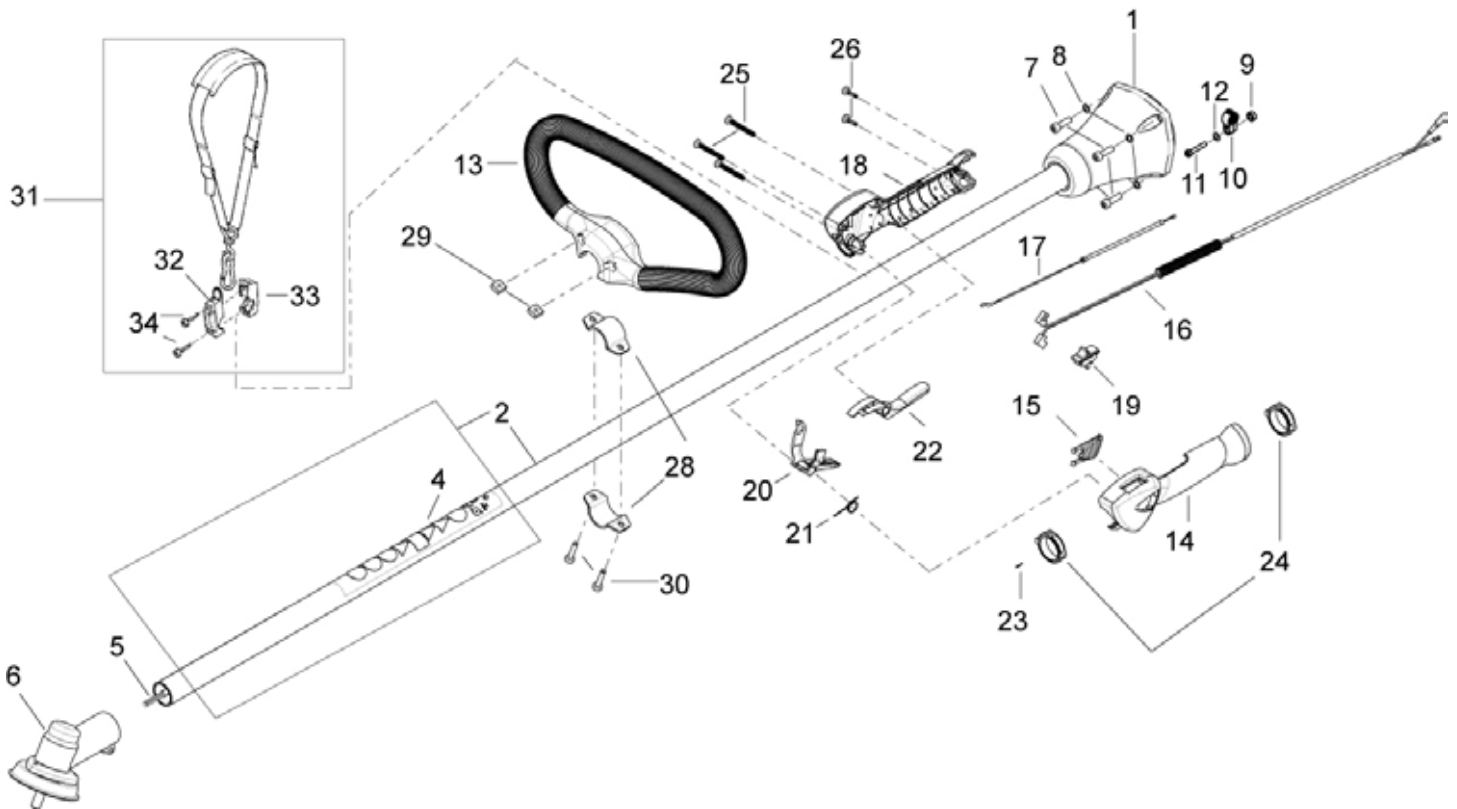
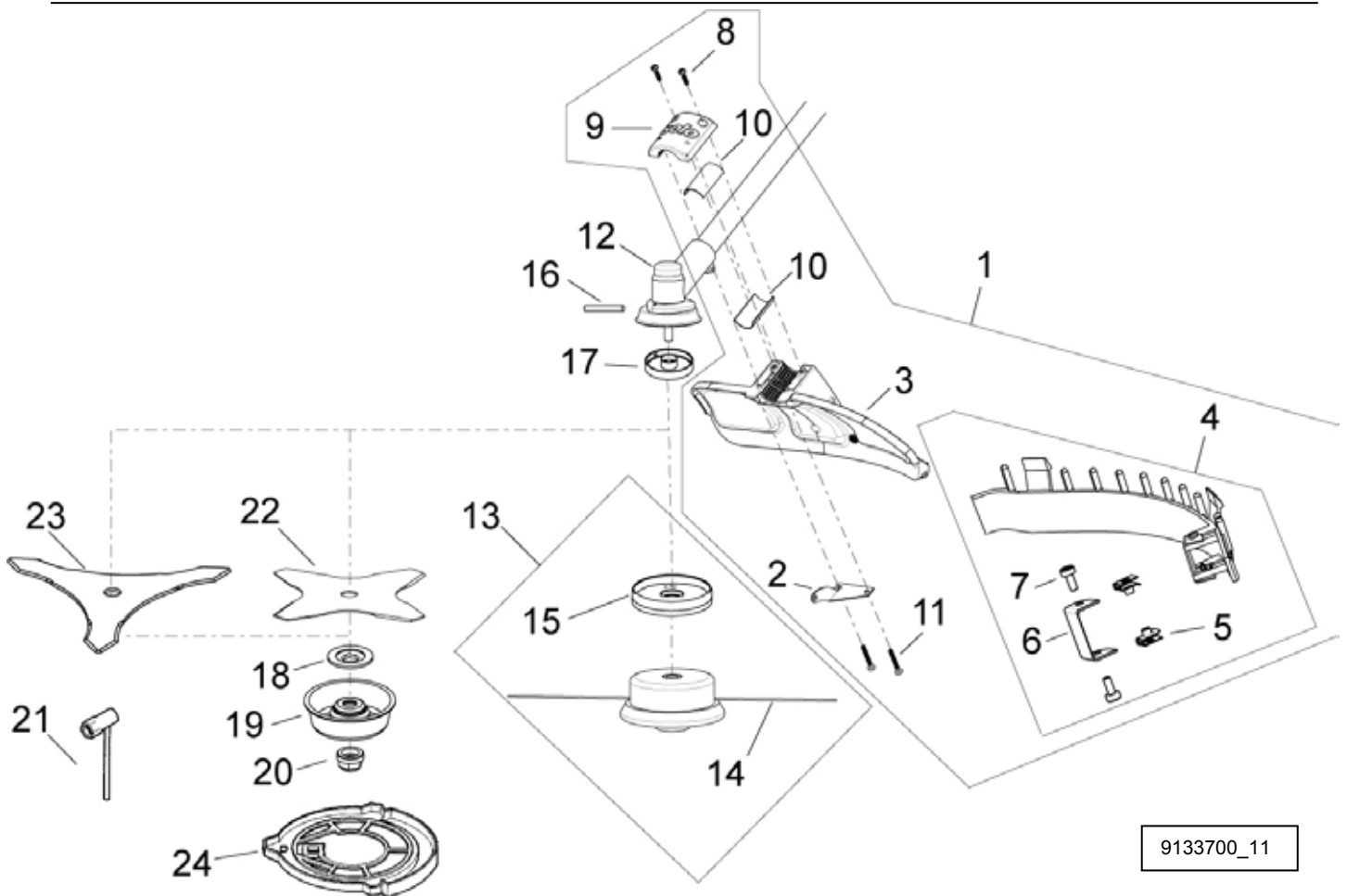
Bestell-Nr. Order-No. No. de Cde Ref.-Nr.	Menge Quantity Nombres Cantidad	Zubehör o. Abb.	Accessories	Accesories	Accesorios
69 00 160	1	2 Faden Schneidekopf „Jet-Fit“	Cutter head "Jet-Fit"	Tête faucheuse "Jet-Fit"	Cabeza de corte "Jet-Fit"
69 00 166	50	Ersatzfaden „Jet-Fit“ 2,5 x 260 mm	Replacement line for "Jet-Fit" 2,5 x 260 mm	Fil de rechange "Jet Fit" 2,5 x 260 mm	Hilo de recambio "Jet Fit" 2,5 x 260 mm
69 00 175	53 m	Ersatzfaden „Jet-Fit“ 2,5 mm	Replacement line for 2,5 mm	Fil de rechange "Jet Fit" 2,5 mm	Hilo de recambio "Jet Fit" 2,5 mm
00 83 103	100ml	Profi 2T-Motoröl	Special 2-stroke oil	Huile spéciale 2 temps	Aceite especial para motores de 2 tiempos
00 83 104	1l	Profi 2T-Motoröl	Special 2-stroke oil	Huile spéciale 2 temps	Aceite especial para motores de 2 tiempos
00 83 105	1l	Profi 2T-Motoröl in Dosierflasche	Special 2-stroke oil, bottle with metering indicator	Huile spéciale 2 temps, en flacon gradué	Aceite especial para motores de 2 tiempos, en botella plastica con escala dosificadora
27 00 278	1	Kraftstoff Mix-Behälter	Mixing can	Jerrycan	Tanque de mezclar
00 83 163	300 ml	Wartungs-/Pflege-Öl	Oil	Huile	Aceite
00 83 180 25	100 g	Spezial- Getriebefett	Grease	Graisse	Grasa
99 303 000 + Größe (2[s]-6[xxl])	1	Forst- und Landschafts-arbeitsjacke EN 340	Jacket	Veste forestiere	Chaqueta
99 020 95 + Größenindex	1	SOLO Outdoor Bundhose	Zip-off trousers	Pantalon de loisir	Pantalon
99 020 94 + Größenindex	1	SOLO Outdoor Latzhose	Flap trousers	Salopette de loisir	Pantalon con peto
99 305 10 + Größe (36 - 48)	1	Leder Forststiefel	Boots	Bottes forestieres	Zapatos
99 390 1002 (Uni-Größe)	1	Gesichts / Gehörschutzkombination	Ear & face protection	Protection ouie et visage	Protection de oido y faz
99 390 12 + Größenindex	1	Handschuhe SOLO Fit	Gloves SOLO Fit	Gants SOLO Fit	Guantes SOLO Fit

D

Allgemeine Richtlinien für die Bestellung von Original SOLO Ersatzteilen:

Voraussetzung für eine reibungslose Erledigung sind folgende Angaben:

1. Ersatzteil-Bestellnummer
2. Gewünschte Anzahl
3. Typenbezeichnung des Geräts

Diese Ersatzteilliste ist für die Lieferung und Ausstattung von SOLO Erzeugnissen unverbindlich.

Im Interesse der technischen Weiterentwicklung bleiben Konstruktionsänderungen vorbehalten.

GB

General Directions for Ordering Original SOLO Spare Parts:

For correct and diligent processing of your order, please give the following information:

1. Spare Part number
2. Quantity
3. Model and serial number
4. Shipping instructions

Delivery is made in accordance with our general sales and delivery conditions. This spare parts list is non-committal for us with regard to delivery and layout of SOLO products. In favour of technical improvements, design modifications are subject to change without notice.

F

Directives générales pour les commandes de pièces de rechange d'origine SOLO:

Il est indispensable de préciser dans toutes les commandes de pièces:

1. le numéro de référence de la pièce
2. la quantité
3. le type de la machine
4. le mode d'expédition

Les livraisons sont effectuées dans le cadre de nos conditions générales de vente.

Toutes modifications réservées.

E

Directivas Generales de pedido de la firma SOLO:

Por adelantado de un arreglo sin dificultades necesitamos siguientes indicaciones:

1. Número de repuesto
2. Numero de cantidad
3. Modelo y número de serial
4. Instrucción de Envío

Esta lista de repuestos no es obligatoria para los envíos y/o forma de equipo de los productos SOLO.

En el interés del constante desarrollo debemos reservarnos el derecho de cambios.

Bestell-Nr. Order-No. No. de Cde Ref.-Nr.	Menge Quantity Nombres Cantidad	Seite Page Page Pagina
771200516	2	7
771200520	4	2
772140408	4	2
772250535	4	2
772330516	4	4
772340555	2	7
772420514	1	7
775103100	1	5
77110052159	1	2
77110112362	1	7
77110132226	1	7
77110492006	1	6
77110602111	1	6
77110612054	1	6
77110612173	1	2
77110612174	1	7
77110612175	1	6
77110612176	1	6
77110612178	1	6
77110652123	1	7
77120222059	1	6
77130012166	1	3
77130022067	1	3
77130086067	1	3
77130332063	1	3
77130812220	1	10
77131652107	2	9
77131692386	1	9
77132712262	2	2
77140432051	1	6
77140692088	1	8
77140802062	1	2
77140802063	1	2
77140902017	1	6
77150042050	1	6
77160022056	1	6
77160302078	1	6
77160552051	1	6
77160732220	2	5
77160732236	1	6
77161602089	1	6
77161602103	1	6
77180202091	1	7
77180772137	1	7
77210502313	1	5
77210832073	1	6
77211302072	1	5
77211692051	1	5

Bestell-Nr. Order-No. No. de Cde Ref.-Nr.	Menge Quantity Nombres Cantidad	Seite Page Page Pagina
77211712250	1	5
77260112113	1	5
77260112361	1	5
77320852105	1	6
77340012089	1	2
77430282067	1	6
77430282096	1	6
77460752129	1	9
77490192114	1	8
77490432067	1	6
77490492075	2	10
77490602065	1	9
77490692430	1	7
77490802205	1	9
77490882559	1	9
77490892631	1	4
77491192231	1	3
77510012324	1	8
77510482083	1	8
77590662797	1	4
77591012120	1	9
77591062064	1	9
77920092235	4	6
77920092249	4	9
77920092277	2	6
77920092336	1	6
77920092337	4	6
77920092383	3	8
77920092411	1	7
77920152145	1	6
77920262125	2	10
77920262353	2	3
77920332010	2	9
77920332058	2	3
77920332078	1	6
77920431302	2	2
77920432094	1	6
77920432210	2	10
77920452279	2	2
77920492259	2	2
77920552147	1	6
77920632483	1	6
77920702107	1	5
77920712142	1	8
77921442308	1	6
77921442390	1	10
77921452112	1	9
77921452148	2	9

Bestell-Nr. Order-No. No. de Cde Ref.-Nr.	Menge Quantity Nombres Cantidad	Seite Page Page Pagina
77921452150	1	9
77921532128	1	7
77921532135	2	5
77921702041	1	5
77921712073	2	8
77921722060	2	4
77921722091	1	6
77921722100	1	9
77921902157	1	8
77921922149	1	8
77921922165	1	5
77922002064	2	10
77922002074	1	6
77922102101	1	5
77999966089	1	8
00 18 226	3	11
00 18 274	2	11
00 18 276	2	12
00 18 335	2	12
00 18 338	2	11
00 18 357	2	11
00 18 363	2	12
00 18 434	1	11
00 18 453	4	11
00 20 223	1	12
00 21 241	2	11
00 28 157	2	12
00 33 426	1	11
00 34 120	4	11
00 43 107	1	11
00 69 382	1	11
00 72 148	1	11
00 73 437	1	11
00 80 509	1	12
00 80 514 25	1	12
00 84 888	1	11
00 84 901	1	11
00 94 344 25	2	11
00 94 346	2	12
20 42 713	1	12
20 43 510	1	12
20 73 125	1	12
20 73 126	1	12
20 74 260	1	11
20 74 261	1	11
20 74 262	1	11
20 74 870	1	12

Bestell-Nr. Order-No. No. de Cde Ref.-Nr.	Menge Quantity Nombres Cantidad	Seite Page Page Pagina
20 74 899 52	1	11
20 74 935	1	11
20 74 936	1	11
21 00 881	1	11
28 00 592	1	11
30 00 236	1	12
30 00 236	1	11
30 31 500	1	12
30 31 501	1	12
30 43 427	1	12
60 35 392	1	11
60 43 989	2	11
60 73 534	1	12
60 73 549	1	12
63 00 369	1	11
68 00 254	1	11
68 00 255	1	11
68 00 864	1	11
69 00 106	1	12
69 00 107	1	12
69 00 655 6	1	12
69 00 924	1	11
69 00 942	15 m	12
69 00 943	1	12
69 00 947	1	12
69 00 948	1	12