

(D)	Ersatzteilliste	Motorsense	135B	Inhaltsverzeichnis	Seite
				Motor:	2 - 10
				Zylinder, Kurbelgehäuse	2
				Kolben, Kurbelwelle	3
				Haube, Luftführung	4
				Zündung	5
				Vergaser	6
				Luftfilter, Auspuff	7
				Benzintank	8
				Starter	9
				Kupplung	10
				Schaftrohr, Getriebe	11
				Bikegriff, Gasbetätigung	12
				Getriebe, Schutz, Schneidwerkzeug	13
				Zubehör	13
				Richtlinien für die Bestellung	14
(GB)	Spare parts list	Brushcutter	135B	Table of contents	Page
				Engine:	2 - 10
				Cylinder, crankcase	2
				Piston, Crankshaft	3
				Cooling-equipment	4
				Electric-equipment	5
				Carburetor	6
				Air-filter, Muffler	7
				Fuel-tank/fuel-valve	8
				Starter	9
				P.T.O-Equipment	10
				Shaft tube, gear	11
				Handle, throttle control	12
				Gear, protection, cutter	13
				Accessories	13
				Directions for ordering	14
(F)	Liste de pièces de rechange	Debroussailleuses	135B	Table des matières	Page
				Moteur	2 - 10
				Tube, engrenage	11
				Poignée, levier de réglage	12
				Engrenage, protection, outil de coupe	13
				Accessories	13
				Directives pour les commandes	14
(E)	Lista de piezas de recambio	Desbrozadora	135B	Indice	Página
				Motor	2 - 10
				Tubo, engranaje	11
				Tubo, acelerador de gas	12
				Engranaje, proteccion, herramienta de corte	13
				Accesorios	13
				Directivas de pedido	14



Bild-Nr. Pos.-No. No.Pos. Pos.-No.	Bestell-Nr. Order-No. No. de Cde Ref.-Nr.	Menge Quantity Nombres Cantidad	Engine: Cylinder, crankcase
1	771200520	4	BOLT-SOCKET,5X20
2	772140408	4	SCREW-PAN+,-,4X8
3	772210408	1	SCREW-CSK-CROSS,4X8
4	772250530	3	SCREW-PAN-WSP-CROS,5X30
5	77110052160	1	CYLINDER-ENGINE
6	77110612192	1	GASKET
7	77110652130	1	CAP
8	77132722009	2	PLATE
9	77140802064	1	CRANKCASE
10	77140802065	1	CRANKCASE
11	77340012090	1	STAND
12	77920431302	2	PIN
13	77920452058	2	BEARING-BALL,6201C3
14	77920492253	1	SEAL-OIL,ISCD12X22X4.5
15	77920492267	1	SEAL-OIL,ISCD 12X22X4.5F



Bild-Nr. Pos.-No. No.Pos. Pos.-No.	Bestell-Nr. Order-No. No. de Cde Ref.-Nr.	Menge Quantity Nombres Cantidad	Engine: Piston, crankshaft
1	77130012170	1	PISTON-ENGINE
2	77130022059	1	PIN-PISTON
3	77130086045	1	RING-SET-PISTON
4	77130332065	1	BEARING-SMALL END
5	77491192243	1	CRANKSHAFT-ASSY
6	77920262355	2	SPACER,9X15X1.8
7	77920332061	2	RING-SNAP

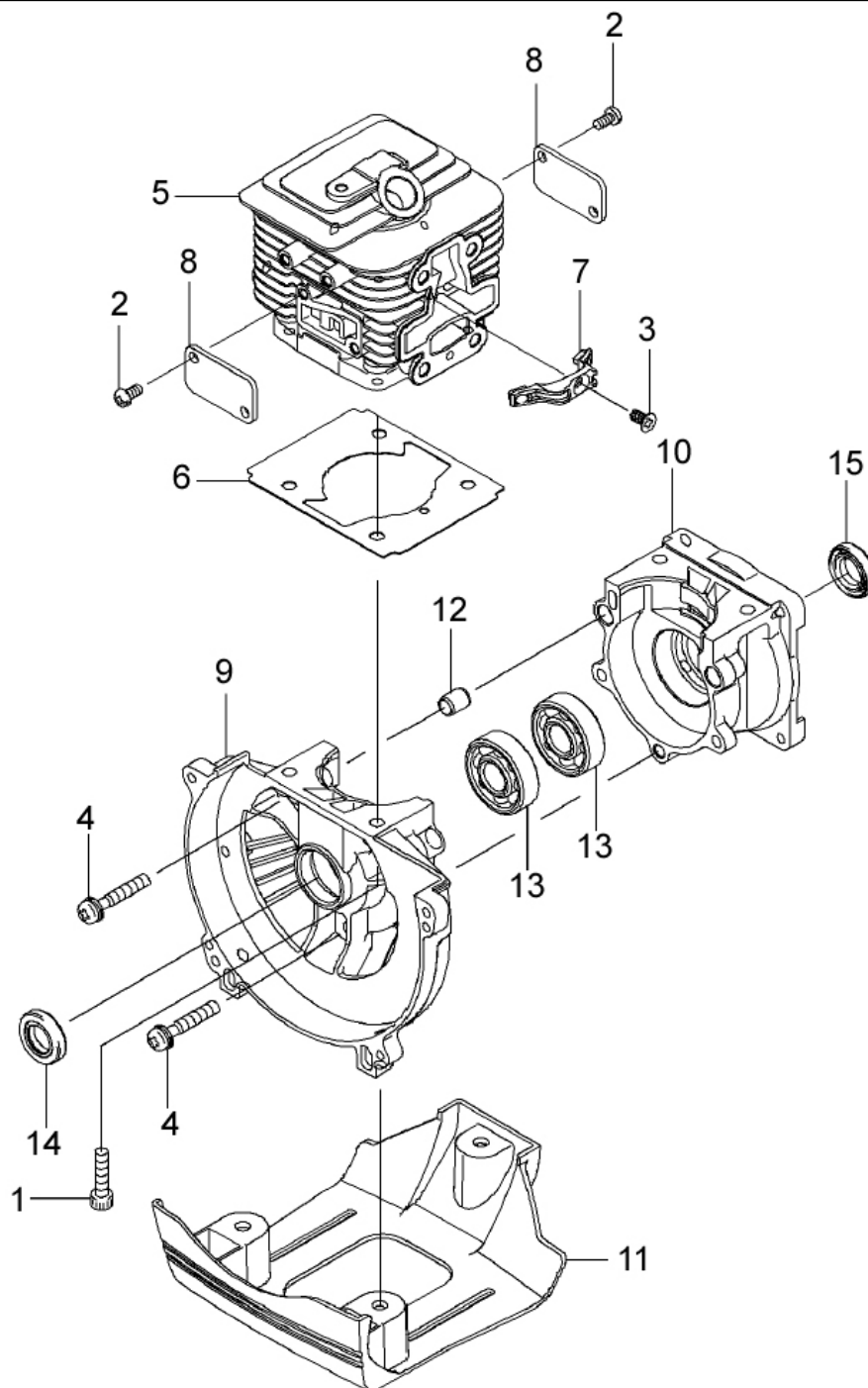

Bild-Nr. Pos.-No. No.Pos. Pos.-No.	Bestell-Nr. Order-No. No. de Cde Ref.-Nr.	Menge Quantity Nombres Cantidad	Engine: Cooling-equipment
1	772330516	4	SCREW-PAN-WP+-.5X16
2	77391562089	1	PAD,SHROUD
3	77490892643	1	SHROUD-ENGINE
4	77590662800	1	HOUSING-FAN
5	77921722060	2	SCREW,4X10

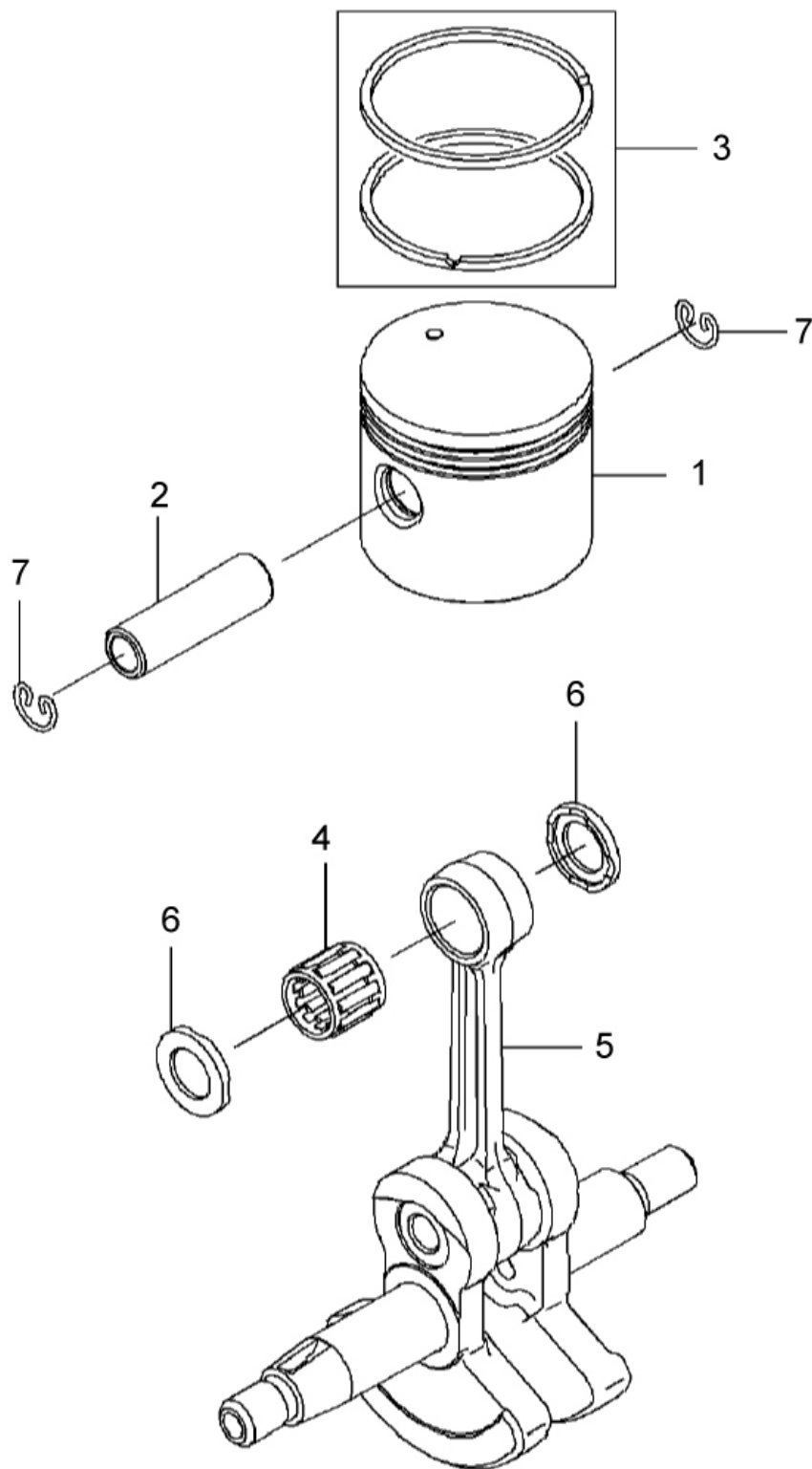

Bild-Nr. Pos.-No. No.Pos. Pos.-No.	Bestell-Nr. Order-No. No. de Cde Ref.-Nr.	Menge Quantity Nombres Cantidad	Engine: Electric-equipment
1	775103100	1	KEY-WOODRUFF
2	77160732220	2	INSULATOR
3	77210502317	1	FLYWHEEL
4	77211302074	1	CAP-SPARK PLUG
5	77211692051	1	TERMINAL
6	77211712257	1	COIL-ASSY-IGNITION
7	77260112113	1	WIRE-LEAD
8	77260112361	1	WIRE-LEAD,L=230
9	77920702107	1	PLUG-SPARK,BPMR7A(NGK),SOLID
10	77921532134	2	BOLT,4X20
11	77921702041	1	CLAMP
12	77921922165	1	TUBE,6X6.6X80
13	77922102094	1	NUT

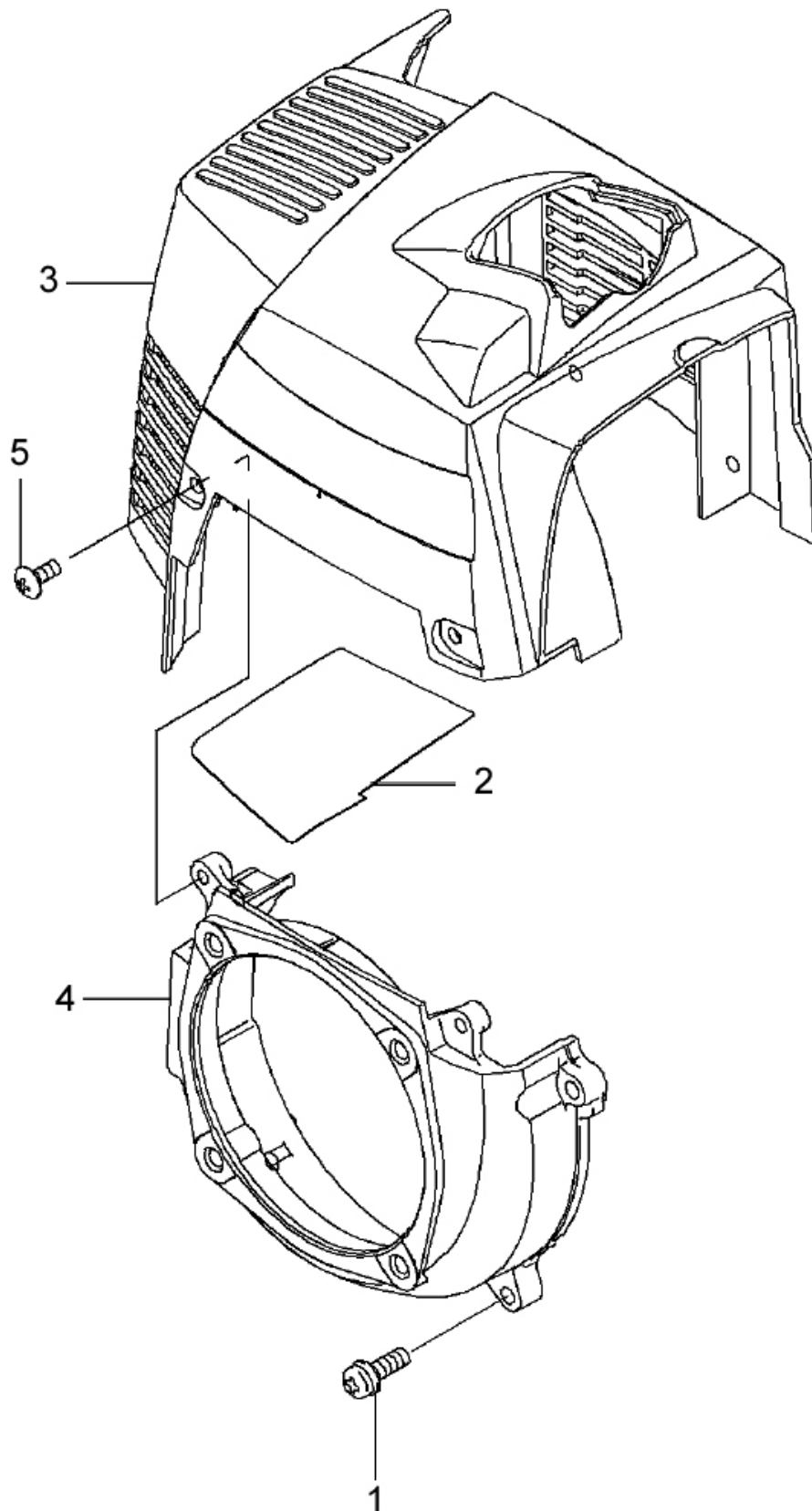

Bild-Nr. Pos.-No. No.Pos. Pos.-No.	Bestell-Nr. Order-No. No. de Cde Ref.-Nr.	Menge Quantity Nombres Cantidad	Engine: Carburetor
1	772340560	2	SCREW-PAN-WSP+-.5X60
2	77110532066	1	BRACKET
3	77110602111	1	GASKET
4	77110612054	1	GASKET
5	77110612208	1	GASKET,CARBURETOR/INSULATOR
6	77110612209	1	GASKET,CYLINDER/INSULATOR
7	77120212055	1	VALVE-ASSY-REED
8	77120222060	1	VALVE-REED
9	77140432051	1	FILTER
10	77140902017	1	COVER,PRIMER PUMP
11	77150042057	1	CARBURETOR-ASSY
12	77160302078	1	VALVE-FLOAT
13	77160552051	1	LEVER
14	77161602089	1	BODY
15	77161602141	1	BODY
16	77210832073	1	ARM
17	77320852106	1	STOPPER
18	77430282067	1	DIAPHRAGM
19	77430282096	1	DIAPHRAGM
20	77430492062	1	PACKING
21	77490432067	1	PUMP-PRIMING
22	77920092249	4	SCREW,5X20
23	77920092277	2	SCREW
24	77920092336	1	SCREW
25	77920092337	4	SCREW
26	77920332078	1	RING-SNAP
27	77920432094	1	PIN
28	77920552147	1	RING-O
29	77920632393	1	JET-MAIN,#37
30	77921442308	1	SPRING
31	77921722091	1	SCREW,3X12
32	77922002074	1	WASHER

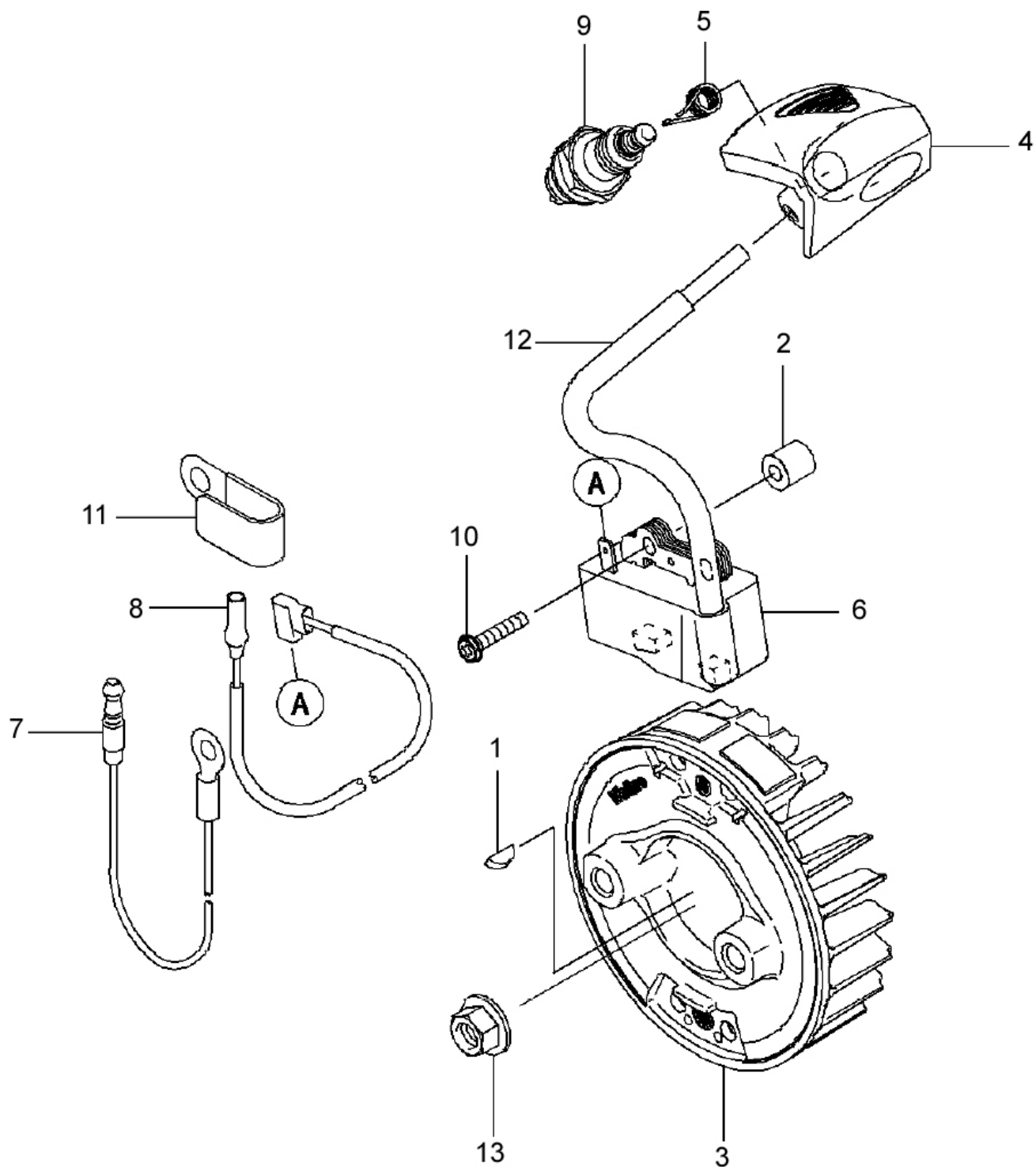

Bild-Nr. Pos.-No. No.Pos. Pos.-No.	Bestell-Nr. Order-No. No. de Cde Ref.-Nr.	Menge Quantity Nombres Cantidad	Engine: Air-filter, Muffler
1	771200516	2	BOLT-SOCKET,5X16
2	772420512	1	SCREW-PAN-WSP+-.5X12
3	77110112366	1	CASE-AIR FILTER
4	77110132229	1	ELEMENT-AIR FILTER
5	77110612193	1	GASKET,MUFFLER
6	77110652125	1	CAP
7	77180202091	1	BAFFLE
8	77180772139	1	ARRESTER-SPARK
9	77490692435	1	MUFFLER-ASSY
10	77920092411	1	SCREW
11	77921532128	1	BOLT

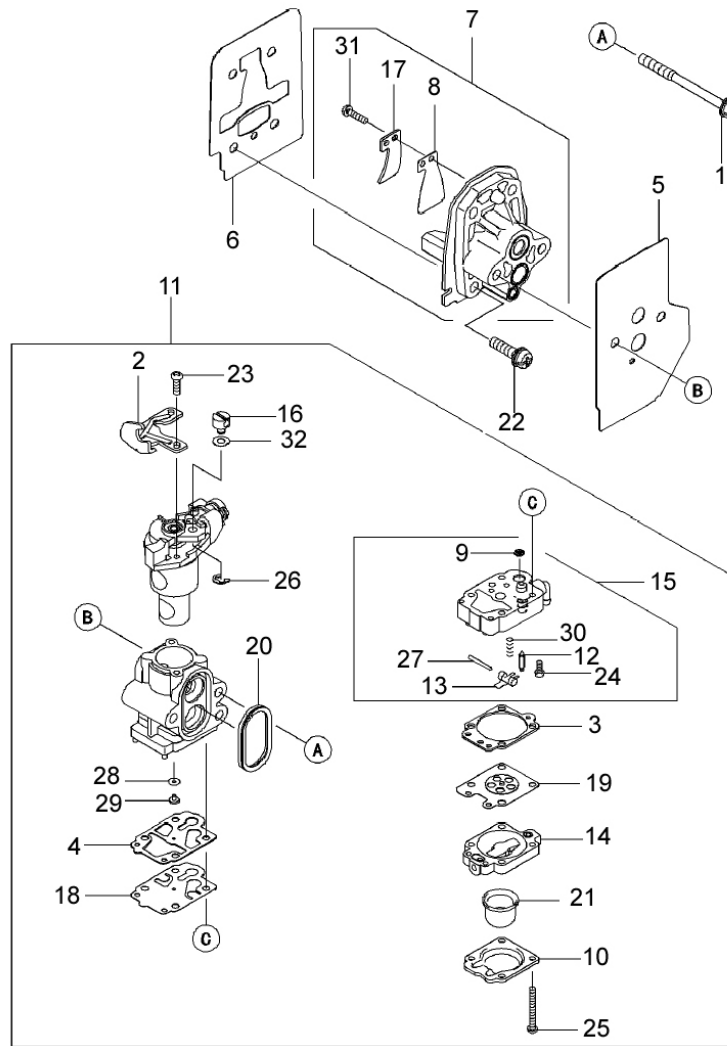

Bild-Nr. Pos.-No. No.Pos. Pos.-No.	Bestell-Nr. Order-No. No. de Cde Ref.-Nr.	Menge Quantity Nombres Cantidad	Engine: Fuel-tank/fuel-valve
1	77140692088	1	BREATHER
2	77490192114	1	FILTER-FUEL
3	77510012336	1	TANK-COMP-FUEL
4	77510482083	1	CAP-ASSY-TANK
5	77920092383	3	SCREW,5X20
6	77920712142	1	GROMMET,FUEL TANK
7	77921712073	2	CLAMP
8	77921912102	1	TUBE,3X5X182
9	77921922117	1	TUBE,3X6X90
10	77999966089	1	CAP-TANK & BREATHER,ASSY

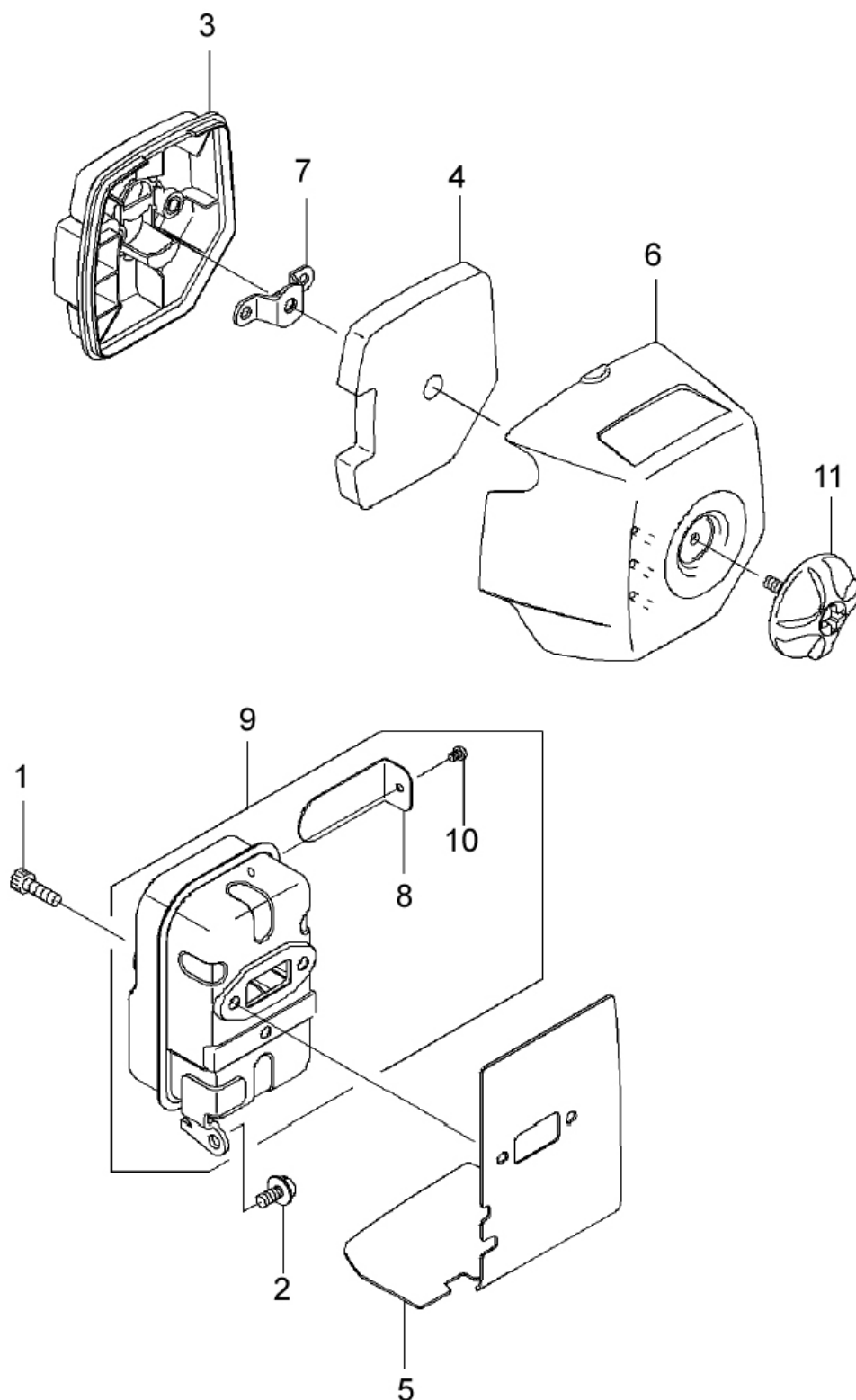

Bild-Nr. Pos.-No. No.Pos. Pos.-No.	Bestell-Nr. Order-No. No. de Cde Ref.-Nr.	Menge Quantity Nombres Cantidad	Engine: Starter
1	77131652103	2	PAWL
2	77131692386	1	PLATE,RECOIL STARTER
3	77320992419	1	CASE,STARTER-RECOIL
4	77460752161	1	GRIP,STARTER-RECOIL
5	77490602062	1	CAM,STARTER-RECOIL
6	77490802201	1	PULLEY-STARTING
7	77490882566	1	STARTER-RECOIL
8	77591012119	1	REEL,STARTER-RECOIL
9	77591062072	1	ROPE,3.5X850
10	77920332010	2	RING-SNAP
11	77921442054	1	SPRING
12	77921442157	2	SPRING
13	77921452149	1	SPRING
14	77921722061	4	SCREW,4X14
15	77921722065	1	SCREW

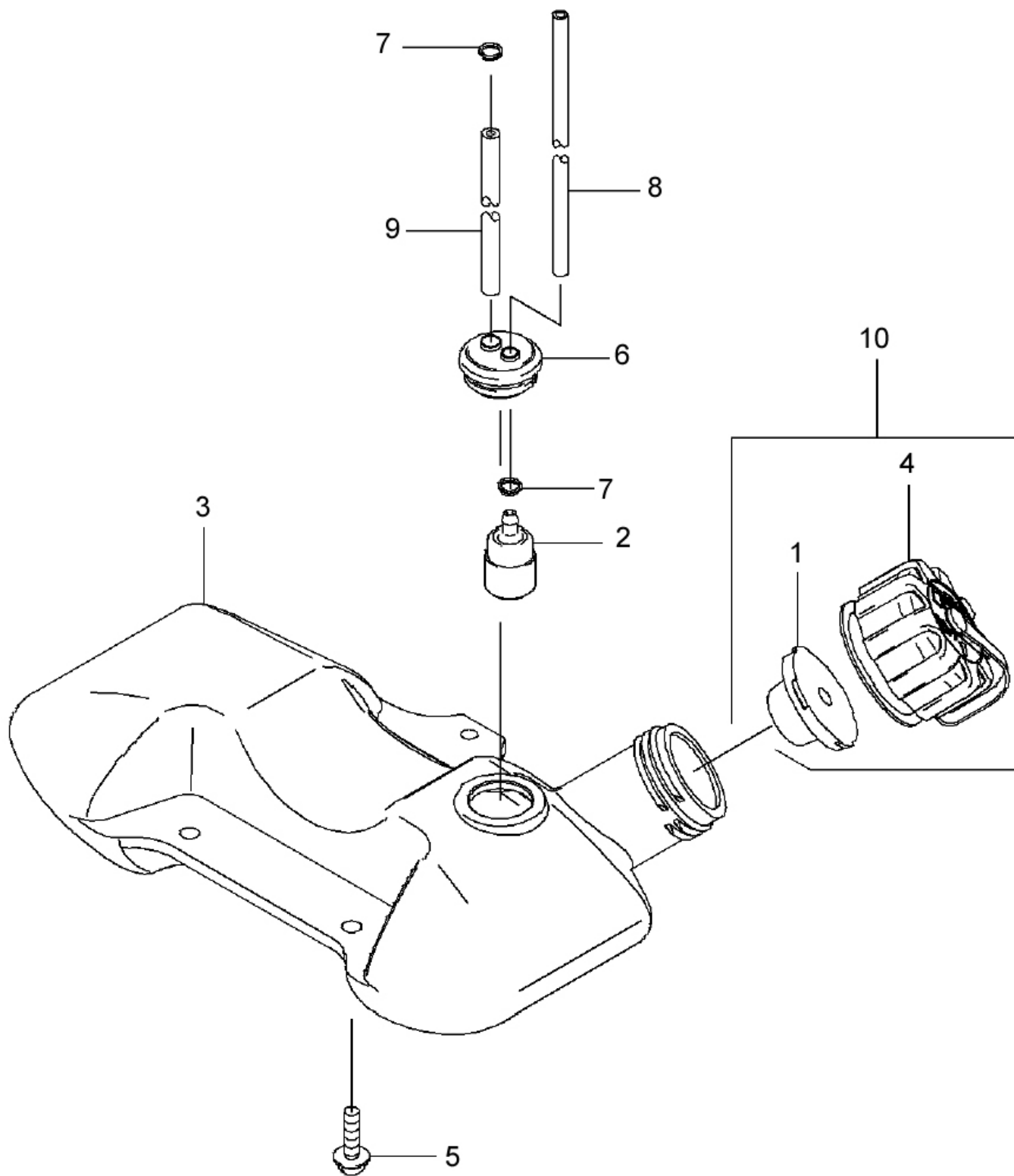

Bild-Nr. Pos.-No. No.Pos. Pos.-No.	Bestell-Nr. Order-No. No. de Cde Ref.-Nr.	Menge Quantity Nombres Cantidad	Engine: P.T.O-EQUIPMENT
1	77130812236	1	CLUTCH-ASSY
2	77490492104	2	SHOE-CLUTCH
3	77920262125	2	WASHER
4	77920432210	2	PIN,CLUTCH
5	77921452178	1	SPRING
6	77922002064	2	WASHER,SPRING,10.5X14.5X0.3

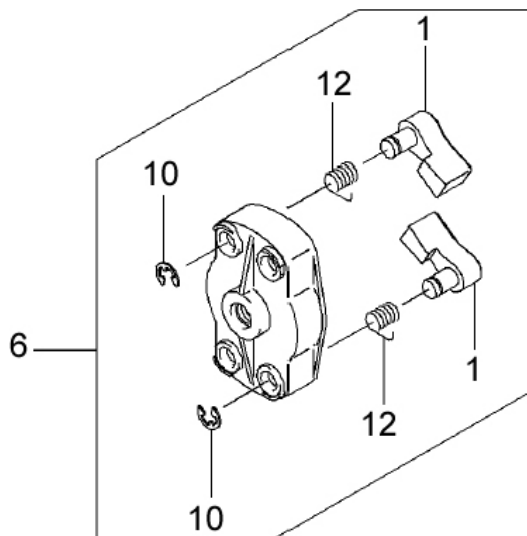
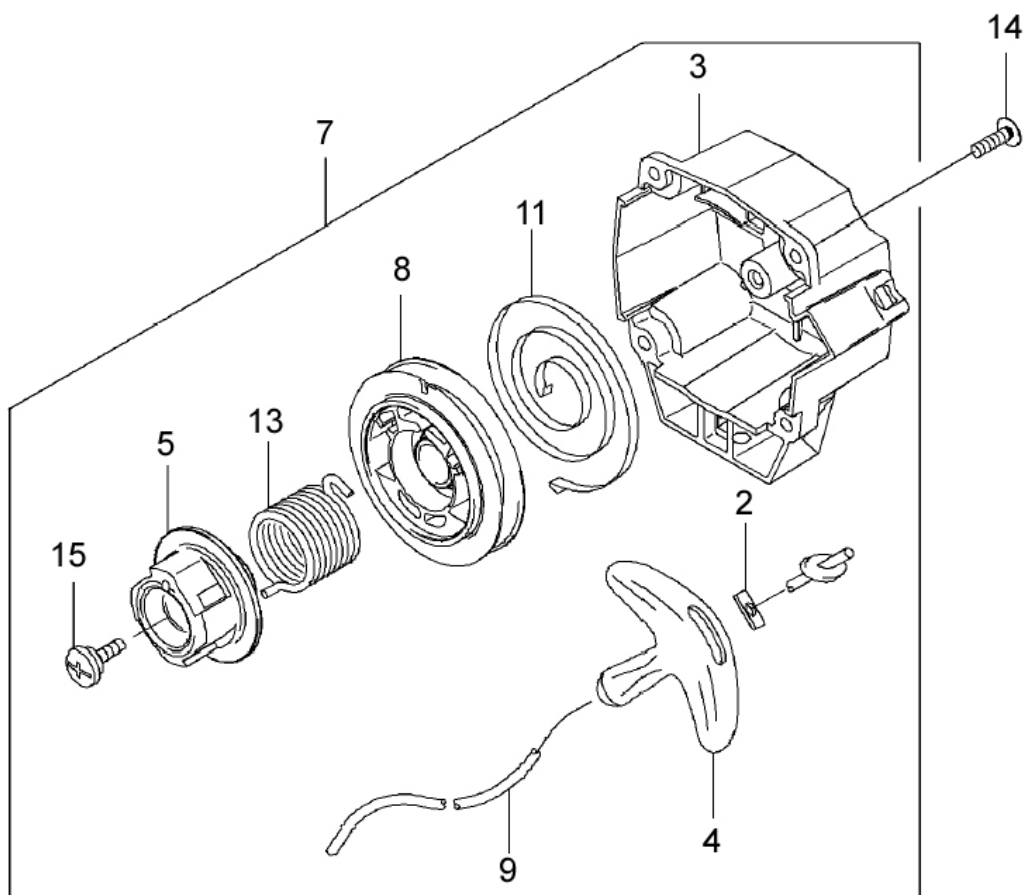

Bild-Nr. Pos.-No. No.Pos. Pos.-No.	Bestell-Nr. Order-No. No. de Cde Ref.-Nr.	Menge Quantity Nombres Cantidad	Schaftrohr, Getriebe	Shaft tube, gear	Tube, engrenage	Tubo, engranaje
1	21 00 881	1	Flanschgehäuse kpl.	Flange housing	Boîtier bride	Caja de brida
2	63 00 369	1	Schaftrohr enth.: (->2 - 4	Shaft tube incl. (->2 - 4	Tube y inclus (->2 - 4	Tubo incl. (->2 - 4
4	00 69 382	1	Aufkleber Warnhinweise (-)	Decal sign	Autocollant	Adhesivo
5	60 35 392	1	Welle 8 x 1553 mm	Drive shaft	Arbre	Arbol
6	30 00 236	1	Getriebe	Gear	Engrenage	Engranaje
7	00 10 252	4	Zylinderschraube M6 x 20 mm	F.H. screw	Vis	Tornillo
8	00 34 120	4	Sicherungsscheibe	Safety washer	Rondelle de sécurité	Arandela seguridad
9	00 33 231	1	Distanzrohr-10x2,3x10 mm	Spacer tube	Tube d' entretoise	Tubo distanciador
10	20 74 899 52	1	Klemme 2	Clamp	Collier	Abrazadera
11	00 18 399	1	Zylinderschraube M5x35 mm	F.H. screw	Vis	Tornillo
12	60 35 370 25	1	Schaftrohr enth.: (->2 - 4	Shaft tube incl. (->2 - 4	Tube y inclus (->2 - 4	Tubo incl. (->2 - 4
13	20 73 693	1	Klemmhalter	Support	Support	Soporte
14	35 00 111	1	Schnellverschluss	Lock	Fermeture	Cierre
15	20 11 859	1	Klemmschale unten	Handle bar clamp cup	Plaque de serrage guidon	Cascara
16	20 11 860	1	Klemmschale oben	Handle bar clamp cup	Plaque de serrage guidon	Cascara
28	60 43 989	2	Schelle 28	Clamp	Collier	Abrazadera
29	00 21 241	2	4KT Mutter M5	Nut	Ecrou	Tuerca
30	00 18 338	2	Zylinderschraube M5 x 25	F.H. screw	Vis	Tornillo
31	63 00 300	1	Doppel-Schultergurt	Double shoulder strap	Bretelles	Doble correa bandolera
32	60 74 529	1	Bowdenzughalter, 28 mm	Bowden cable support	Collier de serrage	Soporte de cable bowden

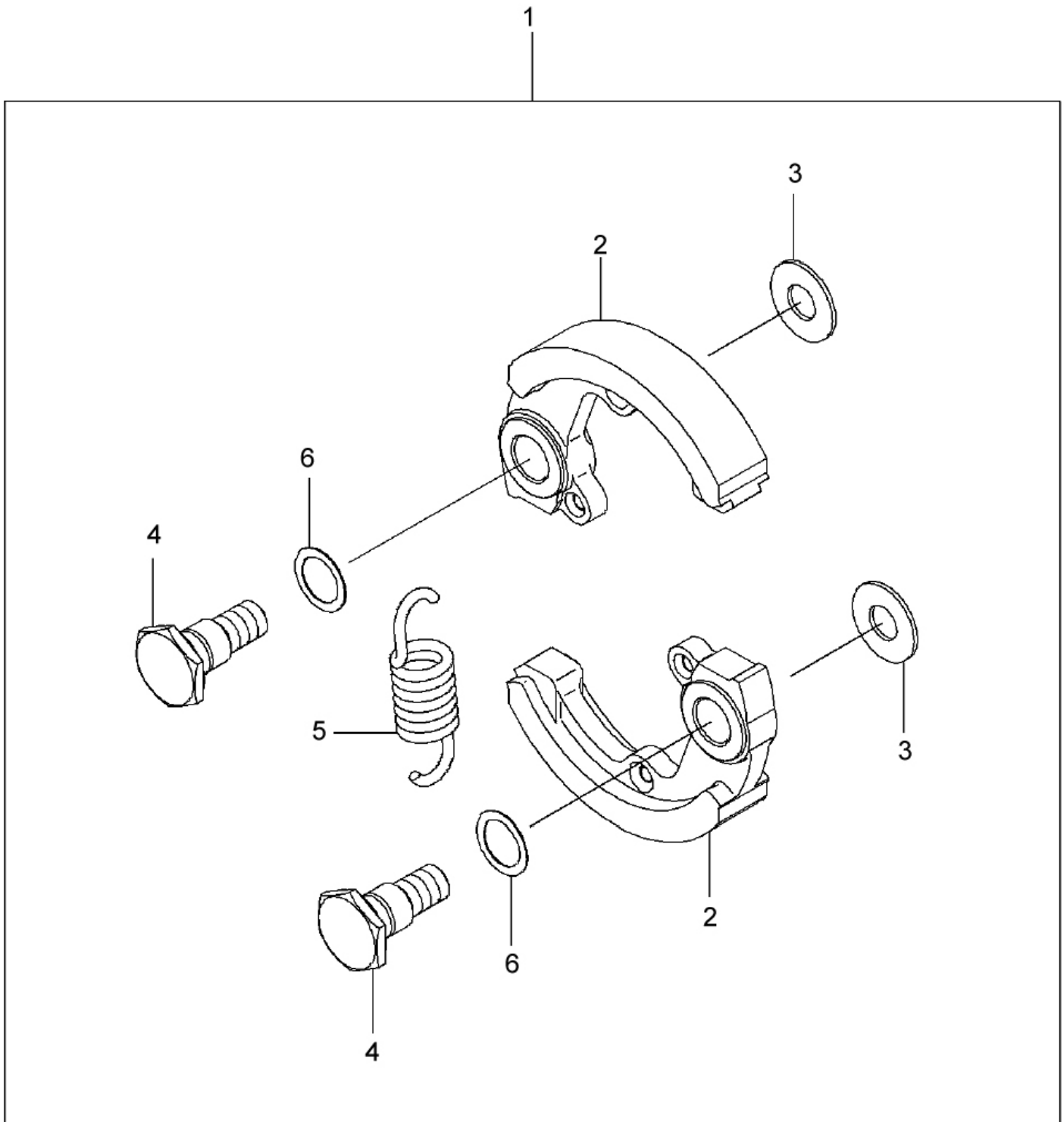

Bild-Nr. Pos.-No. No.Pos. Pos.-No.	Bestell-Nr. Order-No. No. de Cde Ref.-Nr.	Menge Quantity Nombres Cantidad	Bikegriff, Gasbetätigung	Handle, throttle control	Poignée, levier de réglage	Tubo, acelerador de gas
1	68 00 400	1	Gasgriff, kompl. enth. (-> 1 - 14)	Throttle grip, cpl. incl. (-> 1 - 14)	Poignée acc., cpl. y inclus (-> 1 - 14)	Acelerador cpl. incl. (-> 1 - 14)
2	60 73 569	1	Griffhälfte außen rechts	Grip half	Poignée extérieure	Cascara
3	60 73 570	1	Griffhälfte innen rechts	Grip half	Poignée extérieure	Cascara
4	00 73 388	1	Kontaktfeder	Contact spring	Ressort de contact	Resorte
5	00 73 389	1	Kontaktfeder	Contact spring	Ressort de contact	Resorte
6	60 73 572	1	Schieber	Slide	Tiroir	Valvula
7	00 73 387	1	Schenkelfeder 1,3x6, Schieber	Spring	Ressort d'interrupteur	Muelle
8	60 73 573	1	Gashebel	Throttle lever	Levier de gaz	Palanca de gas
9	00 35 158	1	Sicherungsscheibe 4,5x0,3 mm	Safety washer	Rondelle de sécurité	Arandela seguridad
10	00 73 386	1	Schenkelfeder 1x8, Gashebel	Spring	Ressort d'interrupteur	Muelle
11	60 73 571	1	Sicherungshebel	Safety lever	Levier de sécurité	Palanca
12	00 18 356	3	Linsenschraube 4x20 mm	Screw	Vis	Tornillo
13	00 18 364	1	Zylinderschraube M5x32 mm	F.H. screw	Vis	Tornillo
14	00 20 131	1	Sechskantmutter M5 (-)	Nut (-)	Écrou (-)	Tuerca (-)
16	00 84 905	1	Kabel Masse/Kurzschluss	Ground cable	Câble masse	Cable de masa
17	28 00 591	1	Bowdenzug Gas	Throttle cable	Câble des gaz	Cable bowden
18	50 74 100	1	Bowdenzughalter, 22 mm	Bowden cable support	Collier de serrage	Soporte de cable bowden
19	60 35 370 25	1	Bike-Griffrohr 22x1,5 mm	Handlebar	Etrier de maintien	Tubo de palanca
20	60 73 568	1	Griffhälfte innen links	Grip half	Poignée extérieure	Cascara
21	60 73 567	1	Griffhälfte außen links	Grip half	Poignée extérieure	Cascara
22	00 18 356	2	Linsenschraube 4x20 mm	Screw	Vis	Tornillo
23	00 18 364	1	Zylinderschraube M5x32 mm	F.H. screw	Vis	Tornillo
24	00 20 131	1	Sechskantmutter M5	Nut	Écrou	Tuerca
25	35 00 111	1	Schnellverschluss	Lock	Fermeture	Cierre
26	20 11 859	1	Klemmschale unten	Handle bar clamp cup	Plaque de serrage guidon	Cascara
27	20 11 860	1	Klemmschale oben	Handle bar clamp cup	Plaque de serrage guidon	Cascara
28	60 43 989	2	Schelle 28	Clamp	Collier	Abrazadera
29	00 21 241	2	4KT Mutter M5	Nut	Écrou	Tuerca
30	00 18 338	2	Zylinderschraube M5 x 25	F.H. screw	Vis	Tornillo
31	20 73 693	1	Klemmhalter	Support	Support	Soporte

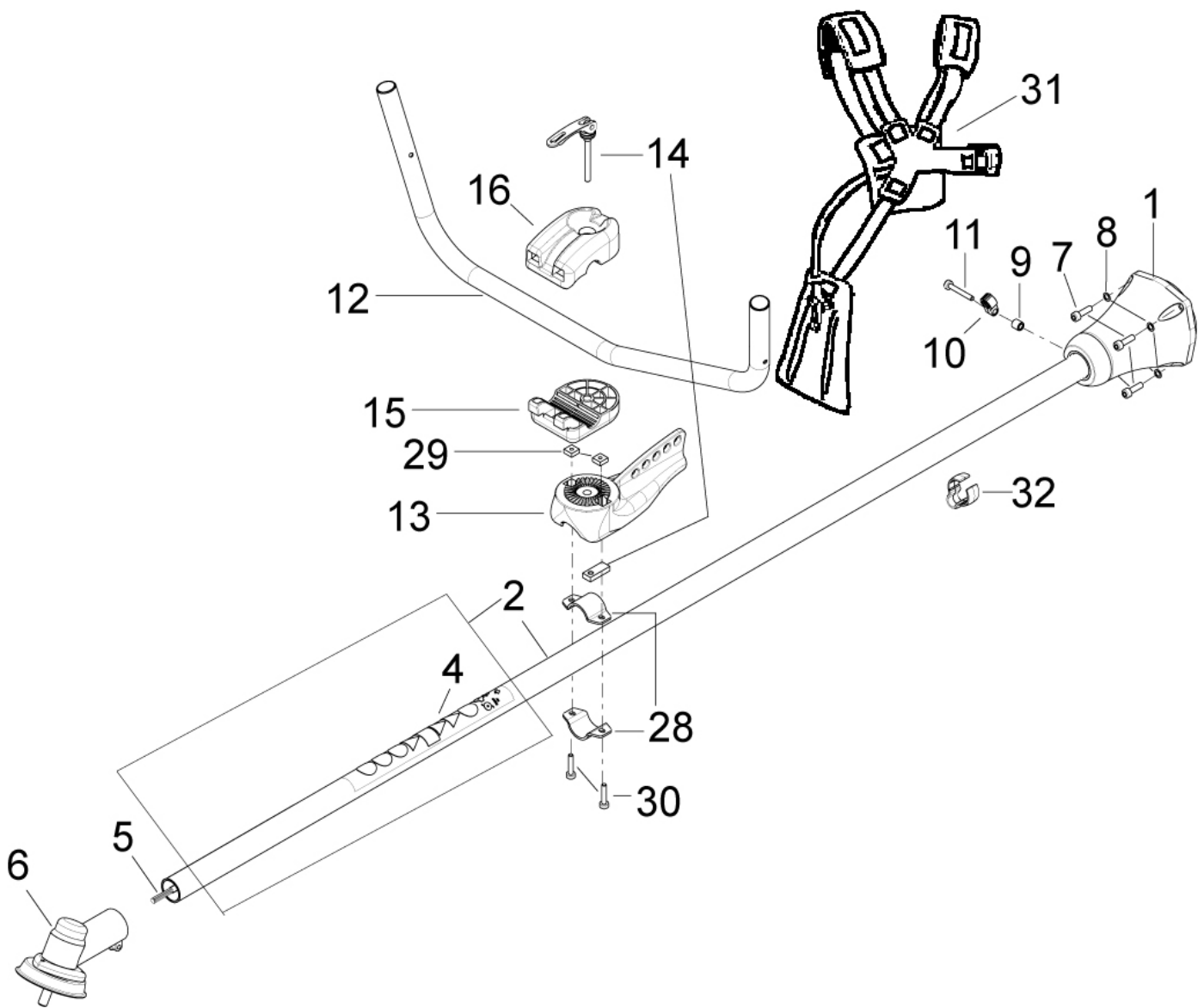

Bild-Nr. Pos.-No. No.Pos. Pos.-No.	Bestell-Nr. Order-No. No. de Cde Ref.-Nr.	Menge Quantity Nombres Cantidad	Getriebe, Schutz, Schneidwerkzeug	Gear, protection, cutter	Engrenage, protection, outil de coupe	Engranaje, proteccion, herramienta de corte
1	69 00 107	1	Schutz komplett enth.: (->1 - 11	Protection incl. (->1 - 11	Protection y inclus : (->1 - 11	Proteccion incl. (->1 - 11
2	20 43 510	1	Abstützung	Support	Support	Soporte
3	20 73 125	1	Schutz	Protection	Protection	Proteccion
4	69 00 106	1	Schutzleiste kpl. enth.: (->4 - 7	Protection rail cpl. incl. (->4 - 7	Listeade protection cpl. y inclus : (->4 - 7	Liston de proteccion cpl incl. (->4 - 7
5	00 28 157	2	Blechmutter	Nut	Ecrou	Tuerca
6	20 42 713	1	Fadenbegrenzungsmesser	Knife	Couteau	Cuchilla
7	00 18 335	2	Zylinderschraube M5x12 mm<-)	F.H. screw <-)	Vis <-)	Tornillo <-)
8	00 18 363	2	PT Schraube 5x20 mm	Screw	Vis	Tornillo
9	20 73 126	1	Deckel	Lid	Couvercle	Tapa
10	00 94 346	2	Zwischenlage 50x40x1 mm	Ply	Piece d'entretoise	Capa intermedia
11	00 18 276	2	PT-Schraube-5x35 mm <-)	Screw <-)	Vis <-)	Tornillo <-)
12	30 00 236	1	Getriebe	Gear	Engrenage	Engranaje
13	69 00 652 6	1	Fadenkopf enth.: (->13 - 15	Nylon head incl. (->13 - 15	Tête fils y inclus : (->13 - 15	Cabezal de hilo incl. (->13 - 15
14	69 00 942	15 m	Ersatzfaden Ø 2,4 mm	Replacement line	Recharge fils	Hilo de recambio
15	20 74 870	1	Wickelschutz <-)	Anti-clogging device <-)	Protecteur d'enroulement <-)	Proteccion de arrollamiento <-)
16	00 80 514 25	1	Montagestift 5 mm	Locking pin	Goupille de montage	Perno
17	30 31 500	1	Druckstück	Pressure part	Pièce de pression	Pieza de presion
18	30 31 501	1	Druckscheibe	Washer	Rondelle	Disco
19	30 43 427	1	Lauffeller	Nut protector	Disque de glissement	Plato de motriz
20	00 20 223	1	Sechskantmutter M10x1,25 mm	Nut	Écrou	Tuerca
21	00 80 509	1	Kombischlüssel SW19/T25	Combi wrench	Clef combi	Llave combi
			Zubehör	Accessories	Accesorios	Accesorios
22	69 00 948	1	Grasschneideblatt, 4 Zähne Ø 230 mm	Grass cutt. Blade 4-t	Lame herbe, 4-dents	Hoja de corte, 4 dientes
23	69 00 947	1	Dickichtmesser 3 Zähne Ø 250 mm	3-tooth brush blade shaft	Lame à broussailles 3 dents	3 cuchilas en forma de Z para matorral
24	60 73 534	1	Transportschutz bis Ø 250 mm	Transport protection	Protection transport	Proteccion transporte
23	69 00 943	1	Dickichtmesser 3 Zähne Ø 300 mm	3-tooth brush blade shaft	Lame à broussailles 3 dents	3 cuchilas en forma de Z para matorral
24	60 73 549	1	Transportschutz bis Ø 300 mm	Transport protection	Protection transport	Proteccion transporte

Bestell-Nr. Order-No. No. de Cde Ref.-Nr.	Menge Quantity Nombres Cantidad	Zubehör o. Abb.	Accessories	Accesories	Accesorios
69 00 160	1	2 Faden Schneidekopf „Jet-Fit“	Cutter head "Jet-Fit"	Tête faucheuse "Jet-Fit"	Cabeza de corte "Jet-Fit"
69 00 166	50	Ersatzfaden „Jet-Fit“ 2,5 x 260 mm	Replacement line for "Jet-Fit" 2,5 x 260 mm	Fil de rechange "Jet Fit" 2,5 x 260 mm	Hilo de recambio "Jet Fit" 2,5 x 260 mm
69 00 175	53 m	Ersatzfaden „Jet-Fit“ 2,5 mm	Replacement line for 2,5 mm	Fil de rechange "Jet Fit" 2,5 mm	Hilo de recambio "Jet Fit" 2,5 mm
00 83 103	100ml	Profi 2T-Motoröl	Special 2-stroke oil	Huile spéciale 2 temps	Aceite especial para motores de 2 tiempos
00 83 104	1l	Profi 2T-Motoröl	Special 2-stroke oil	Huile spéciale 2 temps	Aceite especial para motores de 2 tiempos
00 83 105	1l	Profi 2T-Motoröl in Dosierflasche	Special 2-stroke oil, bottle with metering indicator	Huile spéciale 2 temps, en flacon gradué	Aceite especial para motores de 2 tiempos, en botella plastica con escala dosificadora
27 00 278	1	Kraftstoff Mix-Behälter	Mixing can	Jerrycan	Tanque de mezclar
00 83 163	300 ml	Wartungs-/Pflege-Öl	Oil	Huile	Aceite
00 83 180 25	100 g	Spezial- Getriebefett	Grease	Graisse	Grasa
99 303 000 + Größe (2[s]-6[xxl])	1	Forst- und Landschafts-arbeitsjacke EN 340	Jacket	Veste forestiere	Chaqueta
99 020 95 + Größenindex	1	SOLO Outdoor Bundhose	Zip-off trousers	Pantalon de loisir	Pantalon
99 020 94 + Größenindex	1	SOLO Outdoor Latzhose	Flap trousers	Salopette de loisir	Pantalon con peto
99 305 10 + Größe (36 - 48)	1	Leder Forststiefel	Boots	Bottes forestieres	Zapatos
99 390 1002 (Uni-Größe)	1	Gesichts / Gehörschutzkombination	Ear & face protection	Protection ouie et visage	Protection de oido y faz
99 390 12 + Größenindex	1	Handschuhe SOLO Fit	Gloves SOLO Fit	Gants SOLO Fit	Guantes SOLO Fit

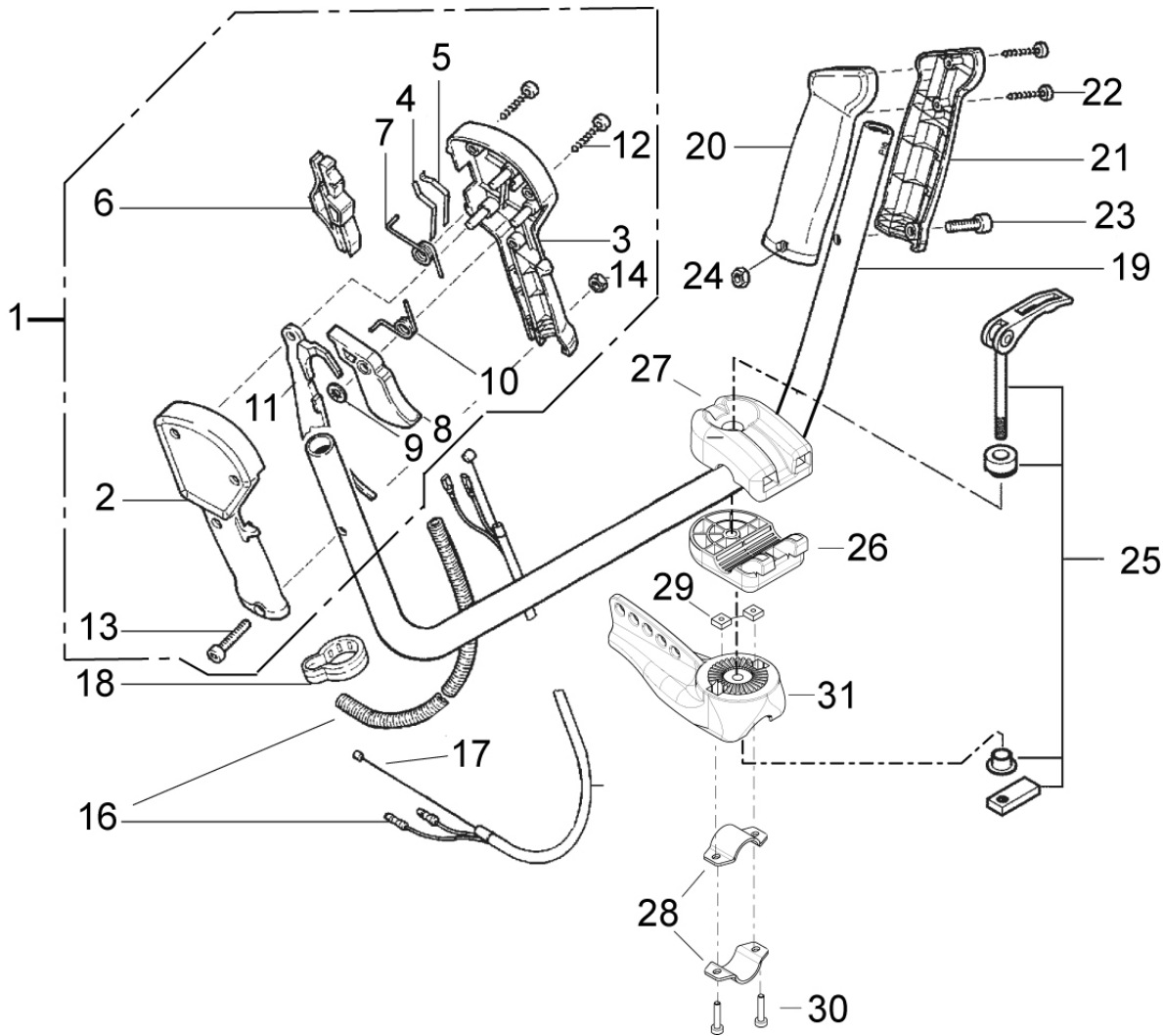
D

Allgemeine Richtlinien für die Bestellung von Original SOLO Ersatzteilen:

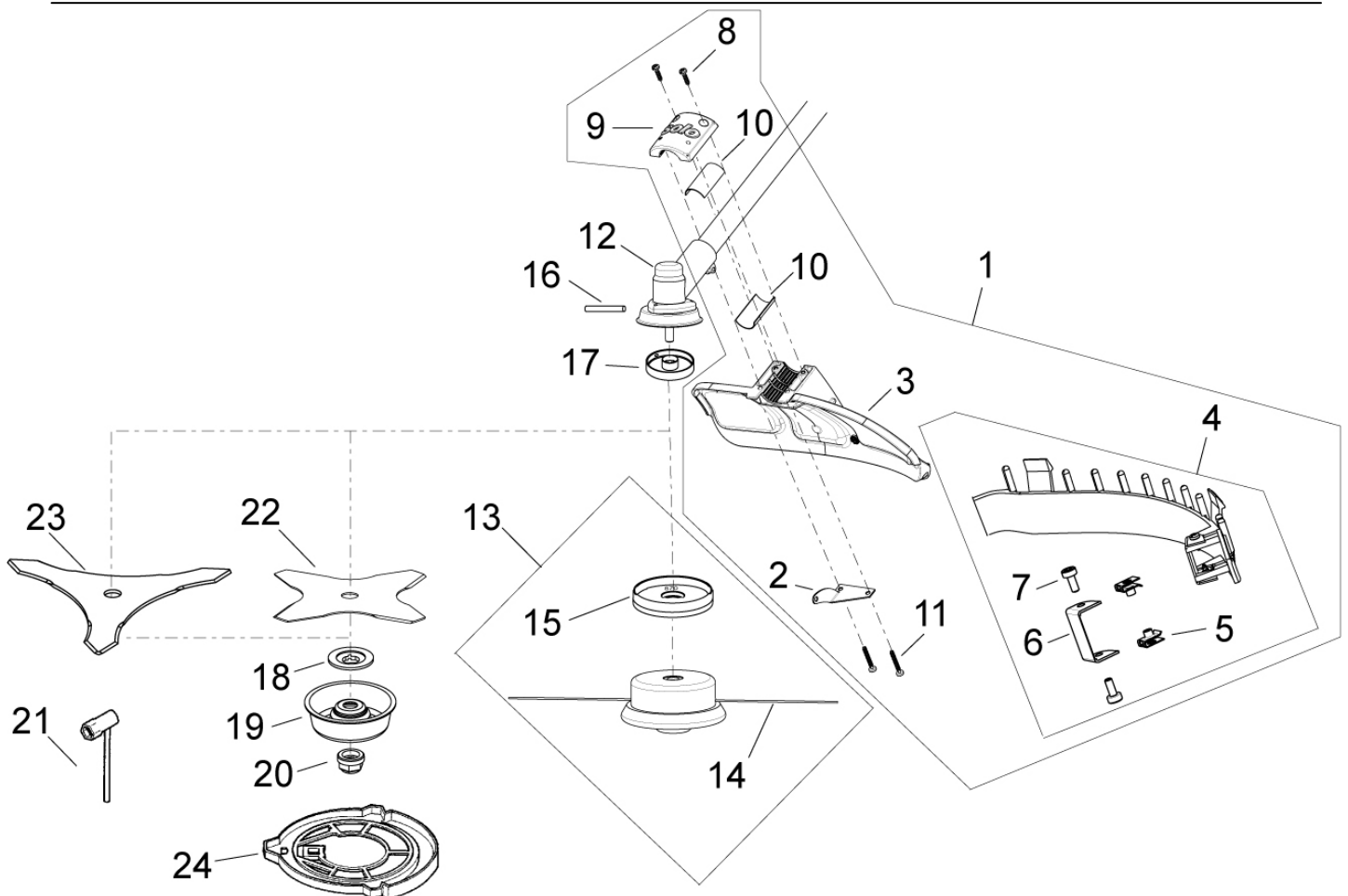
Voraussetzung für eine reibungslose Erledigung sind folgende Angaben:

1. Ersatzteil-Bestellnummer
2. Gewünschte Anzahl
3. Typenbezeichnung des Geräts

Diese Ersatzteilliste ist für die Lieferung und Ausstattung von SOLO Erzeugnissen unverbindlich.

Im Interesse der technischen Weiterentwicklung bleiben Konstruktionsänderungen vorbehalten.

GB

General Directions for Ordering Original SOLO Spare Parts:

For correct and diligent processing of your order, please give the following information:

1. Spare Part number
2. Quantity
3. Model and serial number
4. Shipping instructions

Delivery is made in accordance with our general sales and delivery conditions. This spare parts list is non-committal for us with regard to delivery and layout of SOLO products. In favour of technical improvements, design modifications are subject to change without notice.

F

Directives générales pour les commandes de pièces de rechange d'origine SOLO:

Il est indispensable de préciser dans toutes les commandes de pièces:

1. le numéro de référence de la pièce
2. la quantité
3. le type de la machine
4. le mode d'expédition

Les livraisons sont effectuées dans le cadre de nos conditions générales de vente. Toutes modifications réservées.

E

Directivas Generales de pedido de la firma SOLO:

Por adelantado de un arreglo sin dificultades necesitamos siguientes indicaciones:

1. Número de repuesto
2. Numero de cantidad
3. Modelo y número de serial
4. Instrucción de Envío

Esta lista de repuestos no es obligatoria para los envíos y/o forma de equipo de los productos SOLO.

En el interés del constante desarrollo debemos reservarnos el derecho de cambios.